

P-7926-2

X786

27844

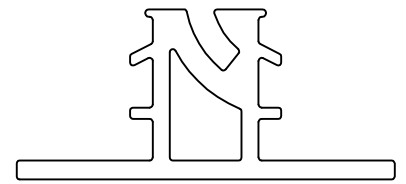

SCALE 1:1

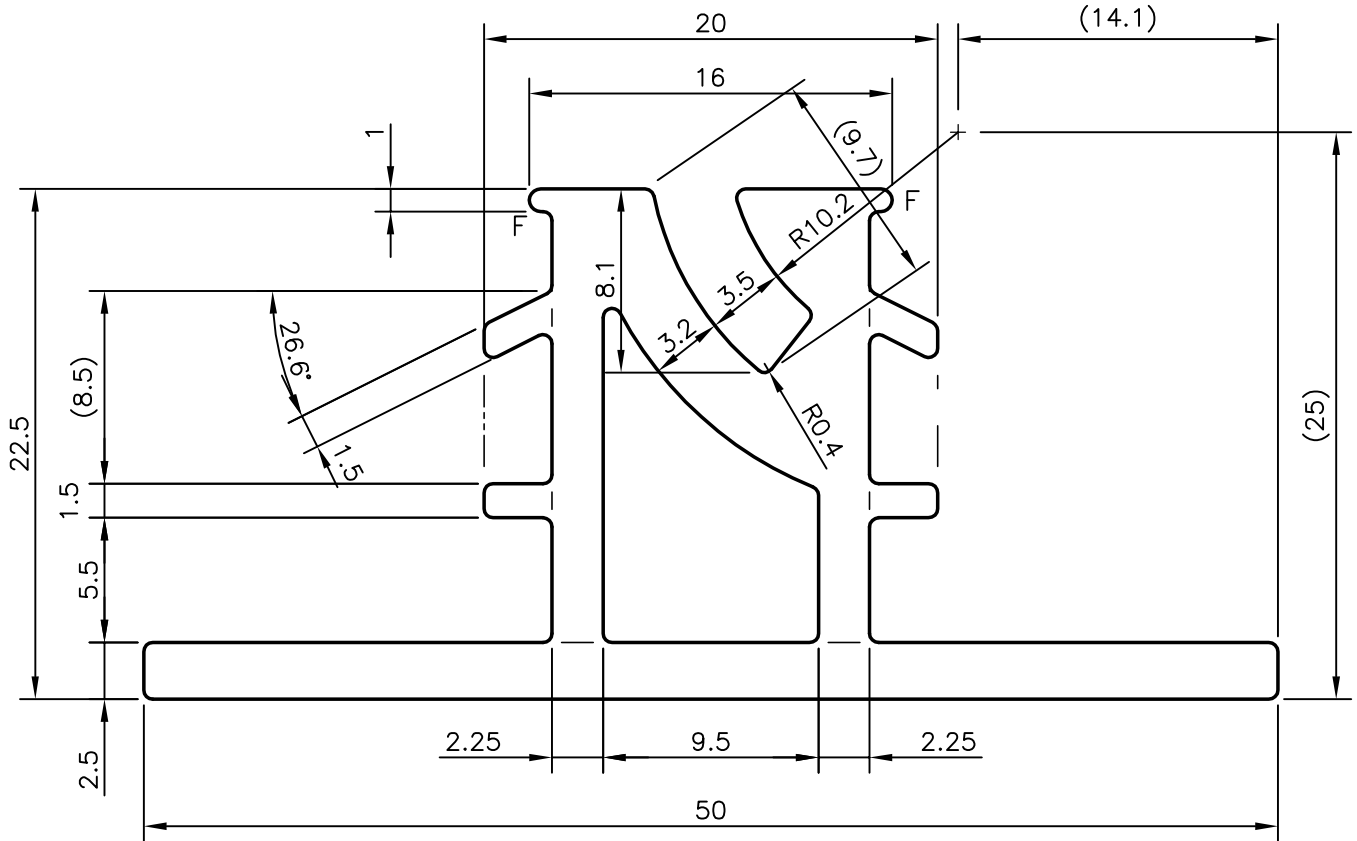

F = FULL RADIUS (2 PLACES)



SYMBOL OF QUALITY
AN ISO 9001 COMPANY

JINDAL ALUMINIUM LTD.
BANGALORE-560073 (INDIA)

	NAME	DATE
DRAWN	PRASANNA.H	10-03-2008
CHECKED		
APPROVED		

1. ALL DIMENSIONS ARE IN mm.
2. ROUND OFF ALL SHARP CORNERS WITH 0.40 mm.
3. TOLERANCES WILL BE AS PER IS:6477-1983 UNLESS OTHERWISE SPECIFIED

SCALE	3:1
AREA mm ²	301.008
PERIMETER mm.	184.404
WEIGHT kg/m	0.813

PARTY'S NAME	PAL ENGINEERING COMPANY, BANGALORE
PARTY'S DRAWING No.	PROFILE NO.1
ALLOY & TEMPER	HE9 WP
DESCRIPTION	MISC. SECTION

DRAWING No.	SECTION No.
P-7926-2	-
X786	X786
27844	27844