

P-9092-1

S2089

27858

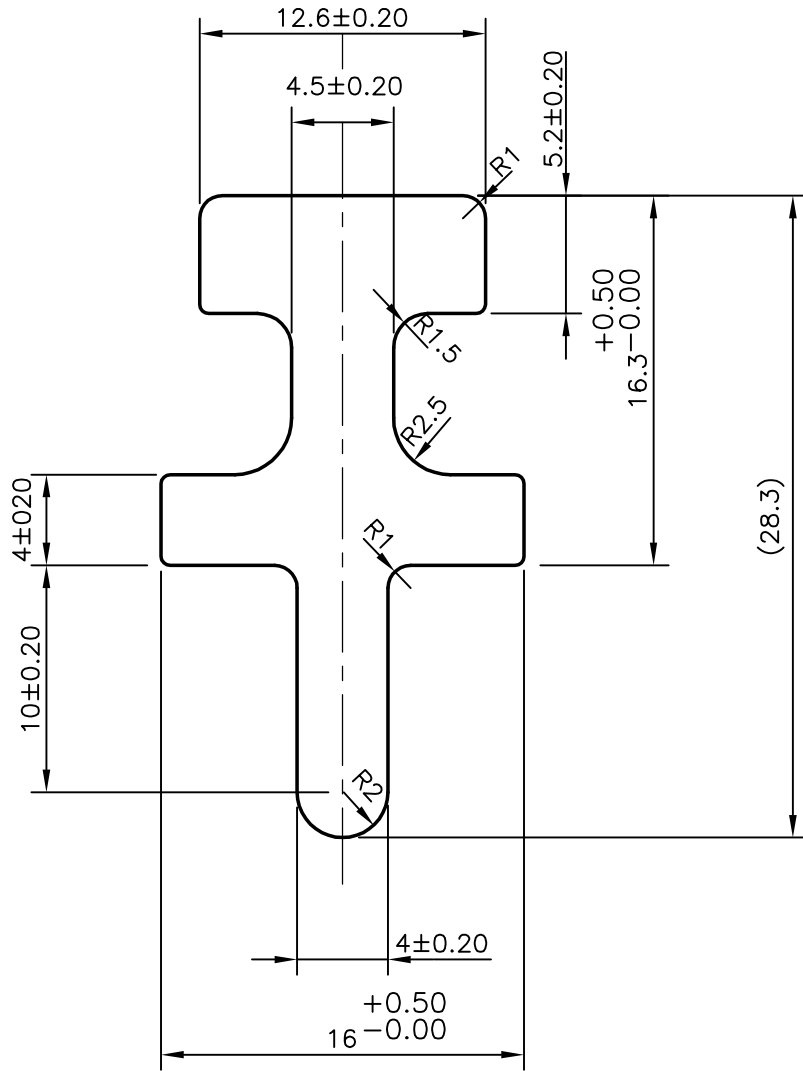
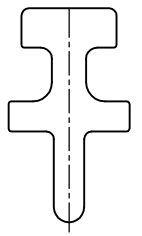

SYMBOL OF QUALITY
AN ISO 9001 COMPANY

JINDAL ALUMINIUM LTD.
BANGALORE-560073 (INDIA)

	NAME	DATE
DRAWN	J.P.KAUSHIK	03-03-2009
CHECKED		
APPROVED		

1. ALL DIMENSIONS ARE IN mm.
2. ROUND OFF ALL SHARP CORNERS WITH 0.40 mm.
3. TOLERANCES WILL BE AS PER IS:3965-1981 UNLESS OTHERWISE SPECIFIED

SCALE	3:1
AREA mm ²	211.195
PERIMETER mm.	96.903
WEIGHT kg/m	0.570
DRAWING No.	SECTION No.
P-9092-1	-
S2089	S2089
27858	27858

PARTY'S NAME	GLOBAL AUTOTECH LTD.,NOIDA
PARTY'S DRAWING No.	TC-EX-112
ALLOY & TEMPER	3103 'O'
DESCRIPTION	MISC. SECTION