

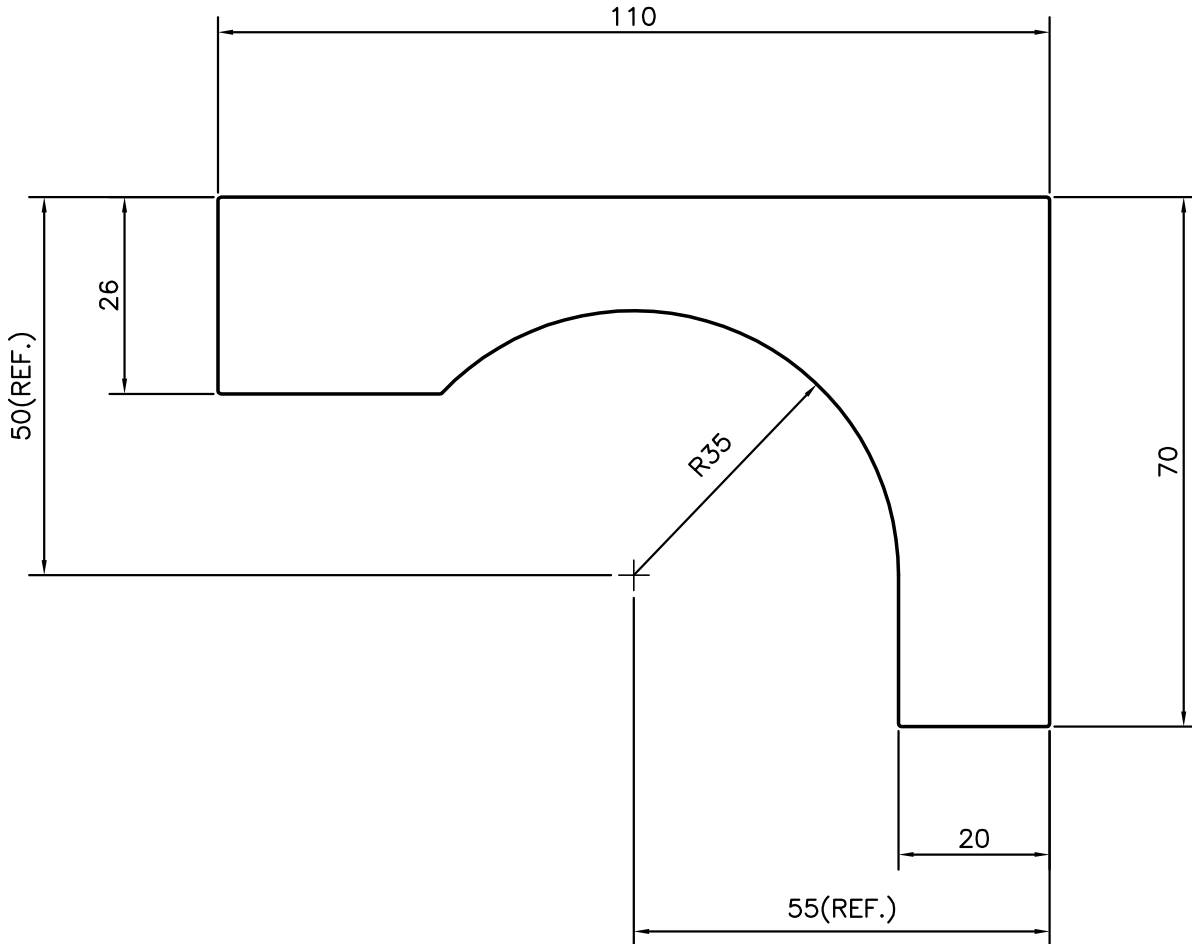

P-10647
S2824
27867



TOLERANCES ON OVERALL WIDTHS & WIDTHS ACROSS FLATS OF BARS, & REGULAR SECTIONS

UPTO 6.40mm - ±0.20	UPTO 32.0mm - ±0.38	UPTO 120.0mm - ±0.85	UPTO 320.00mm - ±1.70
UPTO 10.0mm - ±0.23	UPTO 50.0mm - ±0.46	UPTO 160.0mm - ±1.02	
UPTO 12.0mm - ±0.25	UPTO 60.0mm - ±0.53	UPTO 200.0mm - ±1.14	
UPTO 16.0mm - ±0.28	UPTO 80.0mm - ±0.69	UPTO 250.0mm - ±1.40	
UPTO 25.0mm - ±0.30	UPTO 100.0mm - ±0.75	UPTO 300.0mm - ±1.65	

 SYMBOL OF QUALITY AN ISO 9001 COMPANY	JINDAL ALUMINIUM LTD. BANGALORE-560073 (INDIA)	DRAWN	J.P.KAUSHIK	DATE	15-12-2010
		CHECKED			
1. ALL DIMENSIONS ARE IN mm. 2. ROUND OFF ALL SHARP CORNERS WITH 0.40 mm. 3. TOLERANCES WILL BE AS PER, IS:3965-1981 UNLESS OTHERWISE SPECIFIED		APPROVED	S.S.GARG	DATE	11-01-2011
		SCALE			1:1
PARTY'S NAME AREVA T&D INDIA LTD., CHENNAI		AREA	mm ²		3424.1
		PERIMETER	mm.		358.157
PARTY'S DRAWING No. BL-1088		WEIGHT	kg/m		9.245
		DRAWING No.		SECTION No.	
ALLOY & TEMPER 6060 T6			P-10647		-
			S2824		S2824
DESCRIPTION MISC. SECTION			27867		27867