

| |
|---------|
| P-10823 |
| S2873 |
| 27878 |

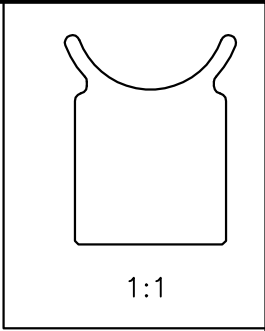

ISSUE-2 :- TOLERANCE CHANGED FROM $R10^{+0.30}_{-0.00}$ TO $R10^{+0.00}_{-0.30}$
& THICKNESS ADDED

ISSUE-3 :- TOLERANCE CHANGED FROM $R10^{+0.00}_{-0.30}$ TO $R10^{+0.10}_{-0.20}$

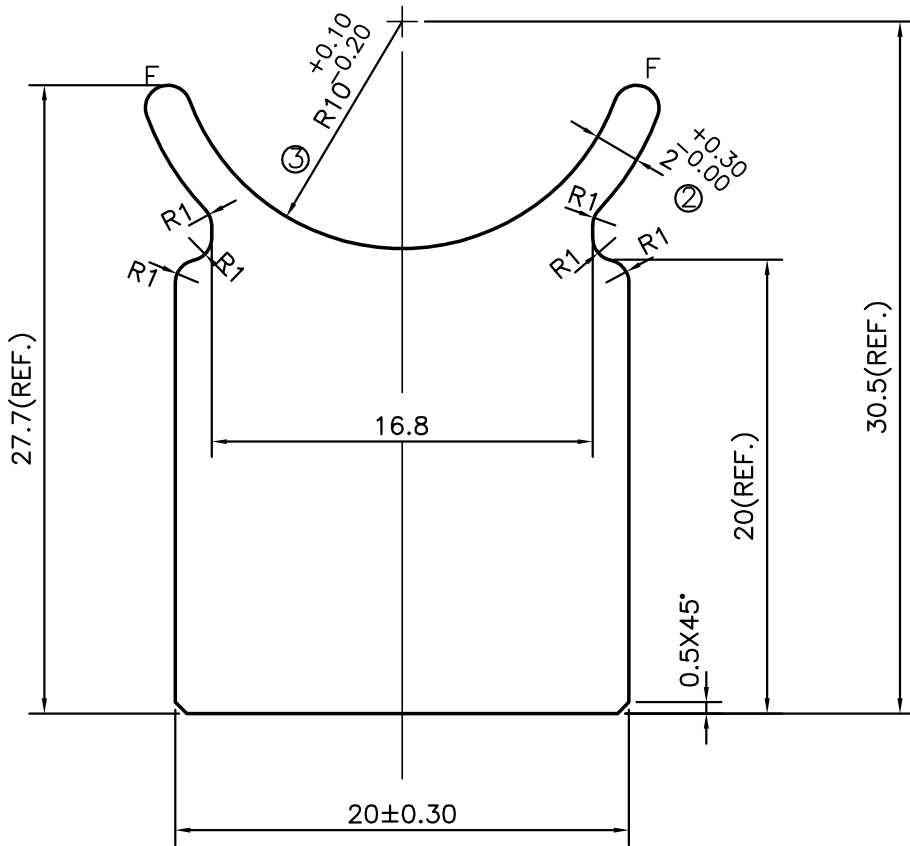

F = FULL RADIUS (2 PLACES)

| | | | | |
|---|--|----------------------|-------------|----------------|
|  SYMBOL OF QUALITY AN ISO 9001 COMPANY | JINDAL ALUMINIUM LTD. BANGALORE-560073 (INDIA) | NAME | | DATE |
| | | DRAWN | J.P.KAUSHIK | 02-06-2011 |
| 1. ALL DIMENSIONS ARE IN mm. 2. ROUND OFF ALL SHARP CORNERS WITH 0.40 mm. 3. TOLERANCES WILL BE AS PER, IS:3965-1981 UNLESS OTHERWISE SPECIFIED | | CHECKED | | |
| | | APPROVED | S.S.GARG | 04-06-2011 |
| PARTY'S NAME WONJIN AUTOPARTS INDIA PVT. LTD., MARAMALAI NAGAR | | SCALE | | 3:1 |
| | | AREA mm ² | | 449.215 |
| PARTY'S DRAWING No. PL F839QQ3 BA01 000 | | PERIMETER mm. | | 106.014 |
| | | WEIGHT kg/m | | 1.213 |
| ALLOY & TEMPER 6005 T6 | | DRAWING No. | | P-10823 |
| | | SECTION No. | | - |
| DESCRIPTION TUBE CONNECTOR SECTION | | S2873 | | S2873(ISSUE-3) |
| | | 27878 | | 27878 |