

P-9342-1

S2174

27880

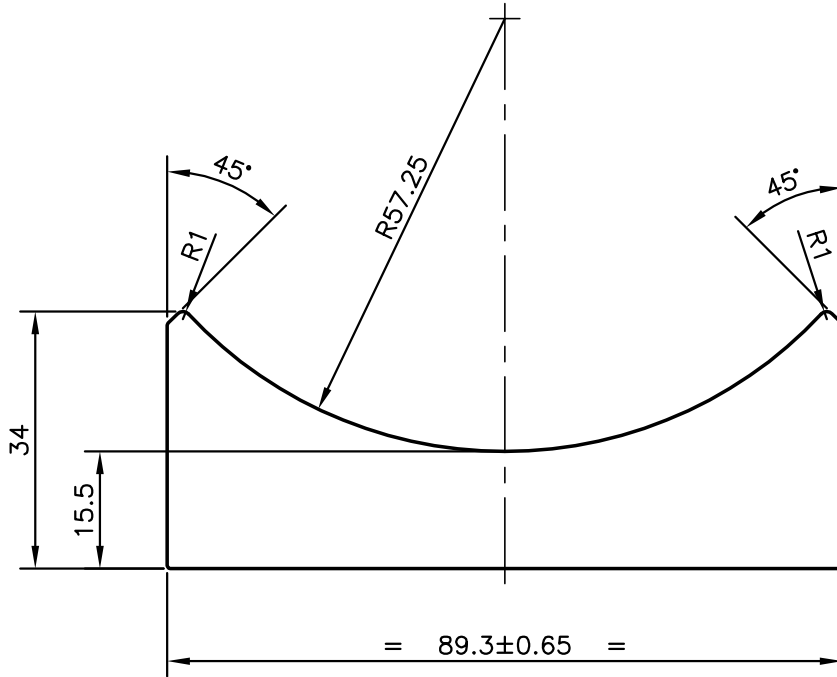

SYMBOL OF QUALITY
AN ISO 9001 COMPANY

JINDAL ALUMINIUM LTD.
BANGALORE-560073 (INDIA)

| | NAME | DATE |
|----------|------------|------------|
| DRAWN | PRASANNA.H | 27-06-2009 |
| CHECKED | | |
| APPROVED | | |

1. ALL DIMENSIONS ARE IN mm.
2. ROUND OFF ALL SHARP CORNERS WITH 0.40 mm.
3. TOLERANCES WILL BE AS PER IS:3965-1981 UNLESS OTHERWISE SPECIFIED

| | |
|----------------------|----------|
| SCALE | 1:1 |
| AREA mm ² | 1954.743 |
| PERIMETER mm. | 254.54 |
| WEIGHT kg/m | 5.278 |

| | |
|---------------------|-------------------------------------|
| PARTY'S NAME | SREE LAKSHMI ENTERPRISES, BANGALORE |
| PARTY'S DRAWING No. | AS PER DRAWING |
| ALLOY & TEMPER | 6061 T6 |
| DESCRIPTION | MISC. BAR |

| DRAWING No. | SECTION No. |
|-------------|-------------|
| P-9342-1 | - |
| S2174 | S2174 |
| 27880 | 27880 |
| | |
| | |