

P-10925-1

S2912

27887

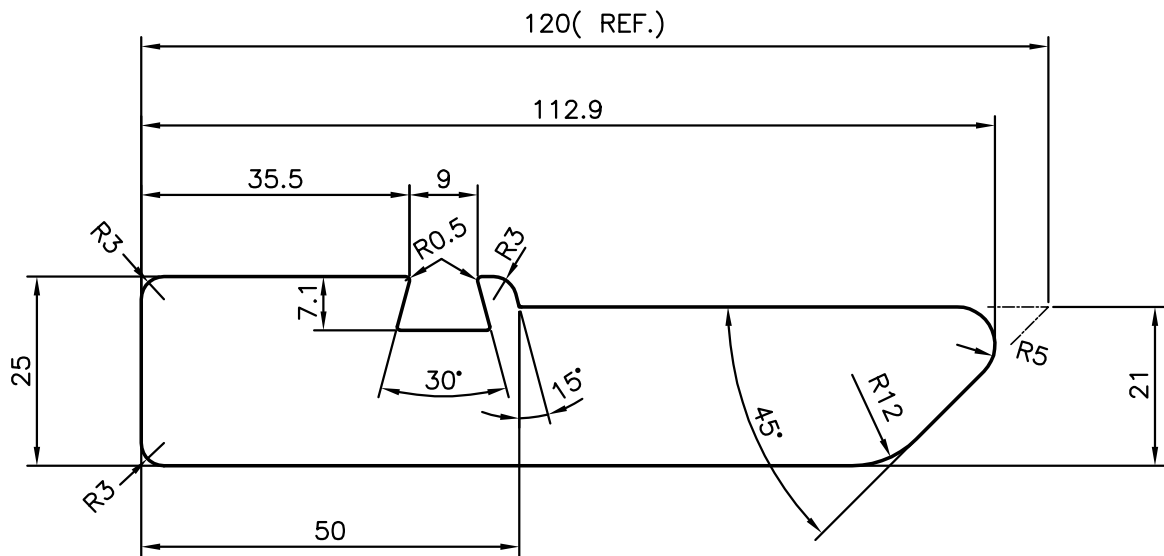

SYMBOL OF QUALITY
AN ISO 9001 COMPANY

JINDAL ALUMINIUM LTD.
BANGALORE-560073 (INDIA)

	NAME	DATE
DRAWN	J.P.KAUSHIK	05-05-2011
CHECKED		
APPROVED	S.S.GARG	12-05-2011
SCALE		1:1
AREA mm ²		2383.171
PERIMETER mm.		277.661
WEIGHT kg/m		6.435
DRAWING No.	SECTION No.	

1. ALL DIMENSIONS ARE IN mm.
2. ROUND OFF ALL SHARP CORNERS WITH 0.40 mm.
3. TOLERANCES WILL BE AS PER IS:3965-1981 UNLESS OTHERWISE SPECIFIED

PARTY'S NAME	WELFAB TECHNOLOGIES PVT. LTD., BANGALORE	P-10925-1	-
PARTY'S DRAWING No.	B31_0152	S2912	S2912
ALLOY & TEMPER	6061 T6	27887	27887
DESCRIPTION	RAIL UPPER CHAMBER		