

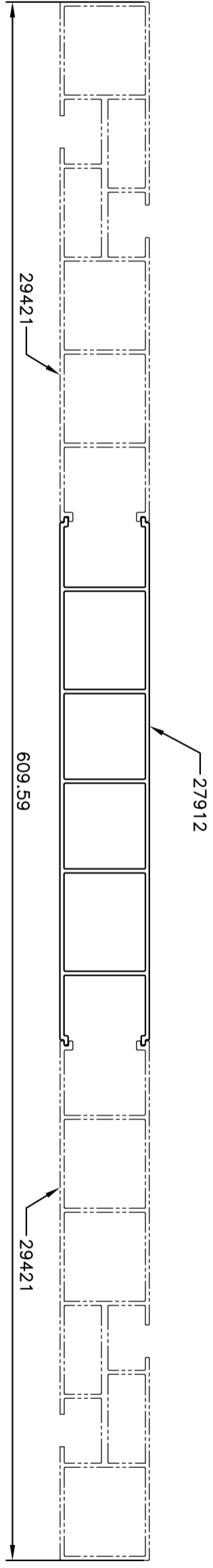

P-10163
S2676
27912

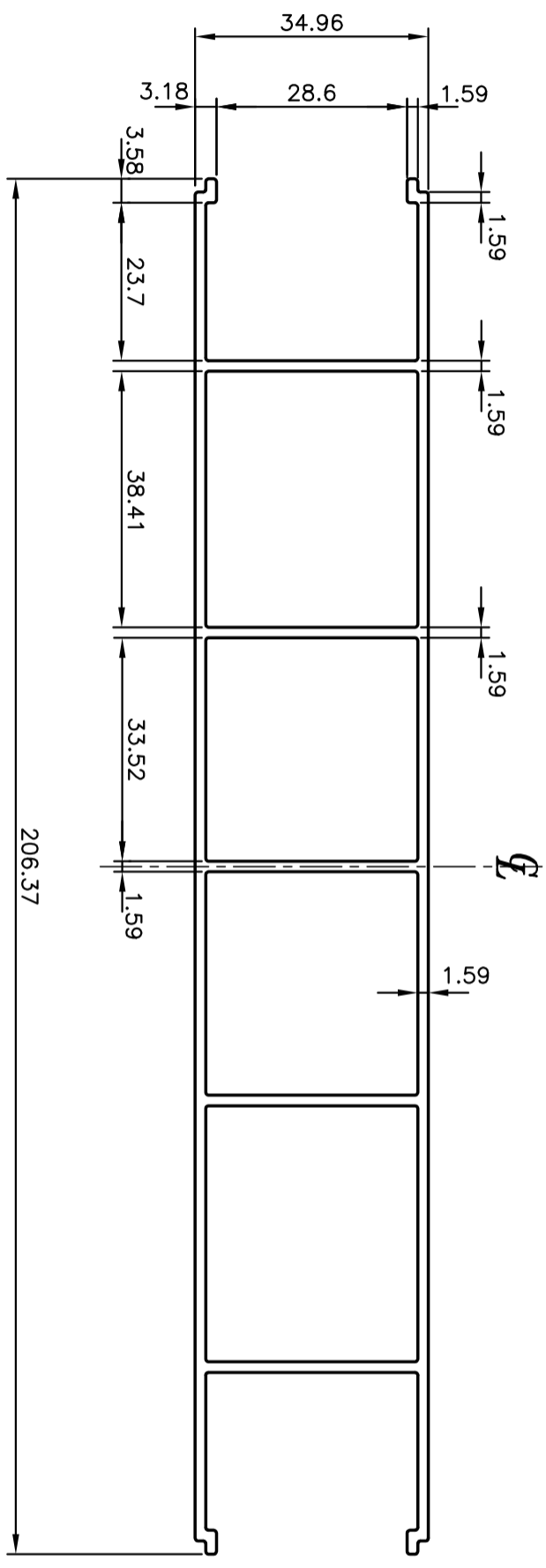

SECTION IS SYMMETRICAL
ABOUT



 SYMBOL OF QUALITY AN ISO 9001 COMPANY	JINDAL ALUMINIUM LTD. BANGALORE-560073 (INDIA)		DRAWN	J.P. KAUSHIK	DATE	06-07-2010
	1. ALL DIMENSIONS ARE IN mm. 2. ROUND OFF ALL SHARP CORNERS WITH 0.40 mm. 3. TOLERANCES WILL BE AS PER BS:EN-12020-2 UNLESS OTHERWISE SPECIFIED		CHECKED			
PARTY'S NAME	EASTMAN INDUSTRIES LTD., LUDHIANA		APPROVED	S.S.GARG		02-09-2010
PARTY'S DRAWING No.	1004-MIS-09-A		SCALE		1:1	
ALLOY & TEMPER	6063 T6		AREA	mm ²	919.432	
DESCRIPTION	MISC. SECTION		PERIMETER	mm.	599.693	
			WEIGHT	kg/m	2.482	
			DRAWING No.		SECTION No.	
			P-10163		-	
			S2676		S2676	
			27912		27912	