

P-9589

X1226

27917

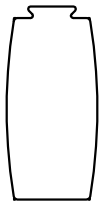

1:1

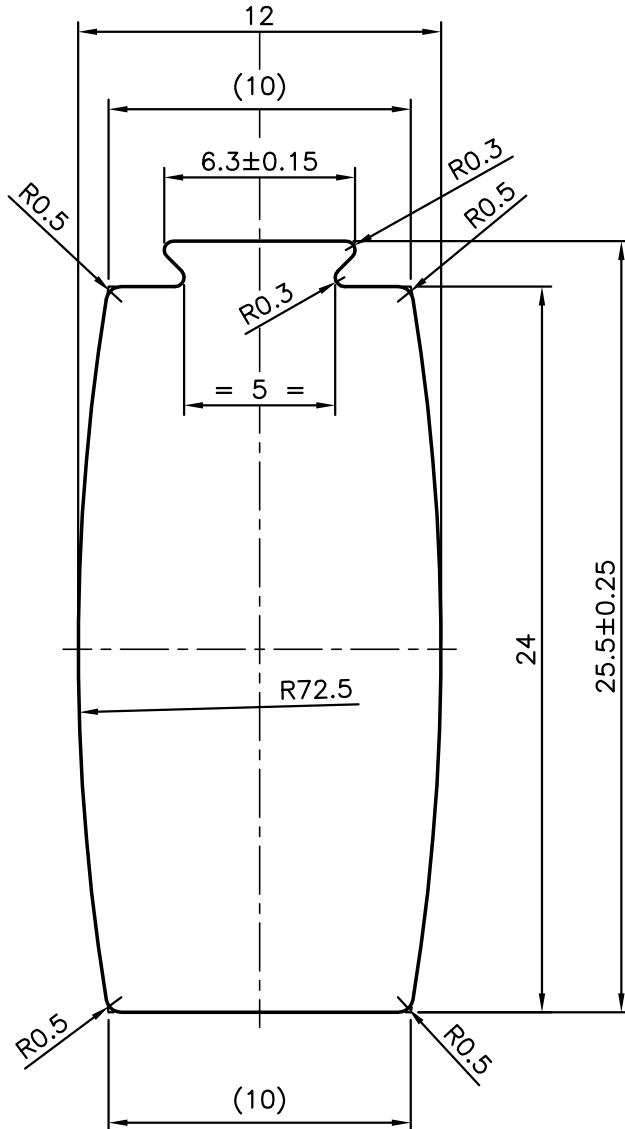

SYMBOL OF QUALITY  
AN ISO 9001 COMPANY

**JINDAL ALUMINIUM LTD.**  
BANGALORE-560073 (INDIA)

	NAME	DATE
DRAWN	J.P.KAUSHIK	27-10-2009
CHECKED		
APPROVED		

1. ALL DIMENSIONS ARE IN mm.
2. ROUND OFF ALL SHARP CORNERS WITH 0.40 mm.
3. TOLERANCES WILL BE AS PER IS:3965-1981 UNLESS OTHERWISE SPECIFIED

SCALE	4:1
AREA mm <sup>2</sup>	280.376
PERIMETER mm.	71.918
WEIGHT kg/m	0.757

PARTY'S NAME	INSYNC RPM PVT. LTD., MUMBAI	DRAWING No.	P-9589	SECTION No.	-
PARTY'S DRAWING No.	R-HNGR-A01-SBAR-0-AL-0-RM	X1226	X1226		
ALLOY & TEMPER	HE9 WP	27917	27917		
DESCRIPTION	MISC. SECTION				