

P-10986-1

S2942

27937

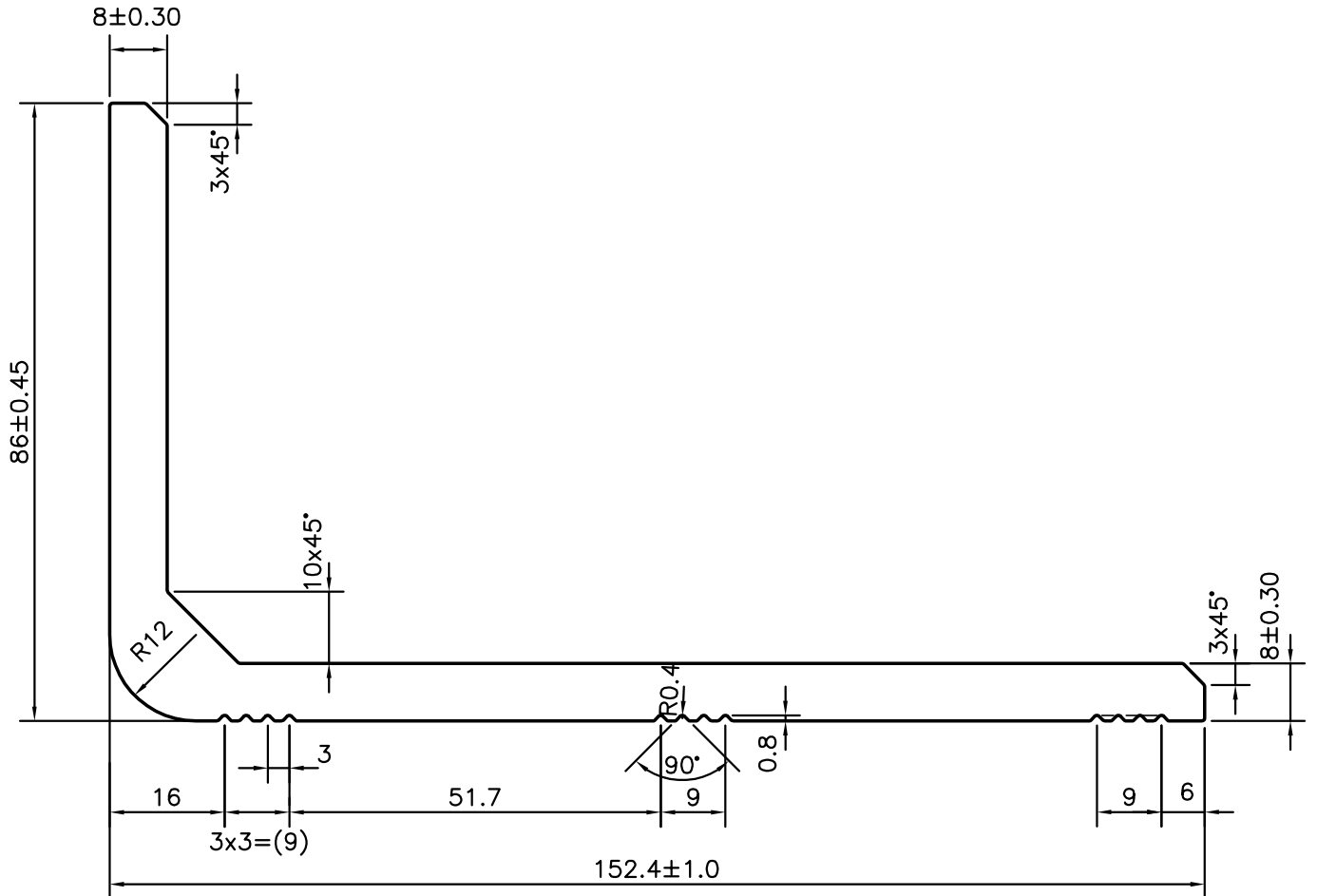

1. STRAIGHTNESS=0.7mm/M
2. TWIST=1.0mm/M
3. ANGULARITY= ±1°
4. FLATNESS =±0.65mm



SYMBOL OF QUALITY
AN ISO 9001 COMPANY

JINDAL ALUMINIUM LTD.
BANGALORE-560073 (INDIA)

	NAME	DATE
DRAWN	J.P.KAUSHIK	26-05-2011
CHECKED		
APPROVED	S.S.GARG	27-05-2011
SCALE		1:1
AREA mm ²		1842.361
PERIMETER mm.		468.957
WEIGHT kg/m		4.974
DRAWING No.	SECTION No.	
P-10986-1	-	
S2942	S2942	
27937	27937	

1. ALL DIMENSIONS ARE IN mm.
2. ROUND OFF ALL SHARP CORNERS WITH 0.40 mm.
3. TOLERANCES WILL BE AS PER, IS:3965-1981 UNLESS OTHERWISE SPECIFIED

PARTY'S NAME	VEER-O-METALS PVT. LTD., BANGALORE
PARTY'S DRAWING No.	20002098
ALLOY & TEMPER	63400 WP
DESCRIPTION	MISC. ANGLE