

P-9576-1

S2367

27939

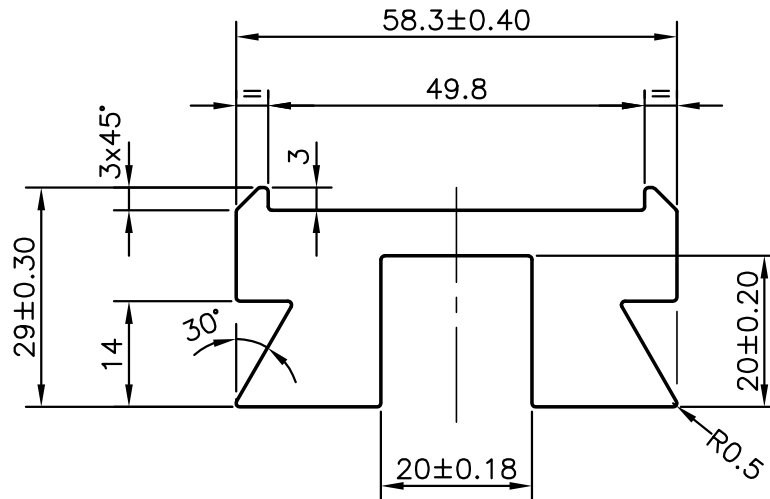

UNSPECIFIED CORNERS RADII:- 0.50 mm.



SYMBOL OF QUALITY
AN ISO 9001 COMPANY

JINDAL ALUMINIUM LTD.
BANGALORE-560073 (INDIA)

| | NAME | DATE |
|----------------------|-------------|------------|
| DRAWN | RAGHAVENDRA | 22-10-2009 |
| CHECKED | | |
| APPROVED | | |
| SCALE | | 1:1 |
| AREA mm ² | | 1029.259 |
| PERIMETER mm. | | 232.61 |
| WEIGHT kg/m | | 2.779 |
| DRAWING No. | SECTION No. | |
| P-9576-1 | - | |
| S2367 | S2367 | |
| 27939 | 27939 | |

1. ALL DIMENSIONS ARE IN mm.
2. ROUND OFF ALL SHARP CORNERS WITH 0.50 mm.
3. TOLERANCES WILL BE AS PER IS:3965-1981 UNLESS OTHERWISE SPECIFIED

| | |
|---------------------|------------------------------|
| PARTY'S NAME | APPASAMY ASSOCIATES, CHENNAI |
| PARTY'S DRAWING No. | AS PER DRAWING |
| ALLOY & TEMPER | 6005 T6 |
| DESCRIPTION | KERATOMETER YOKE SECTION |