

P-11129

S3036

27944

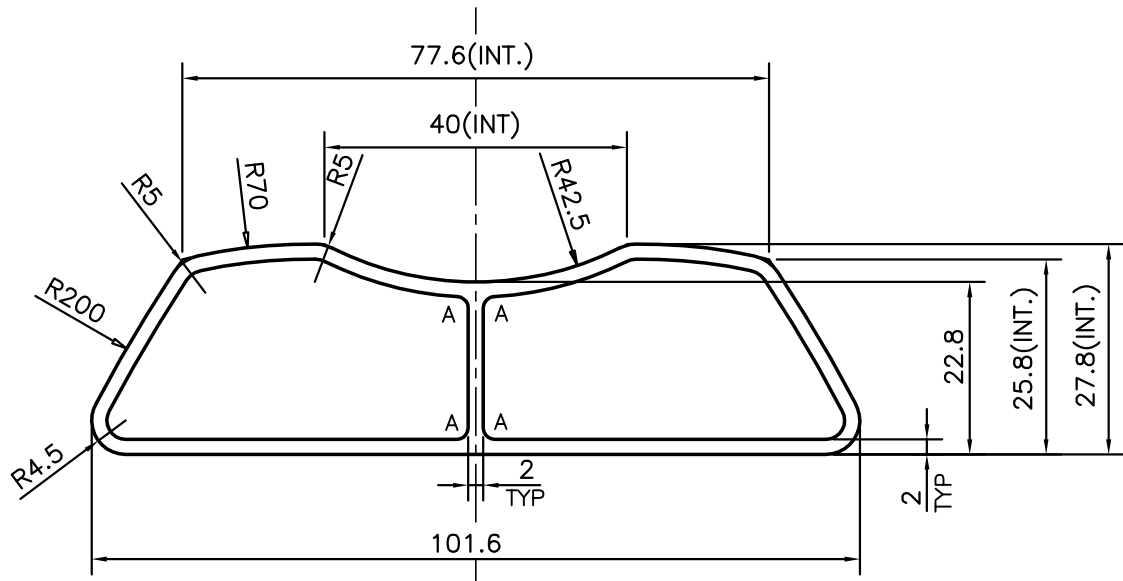
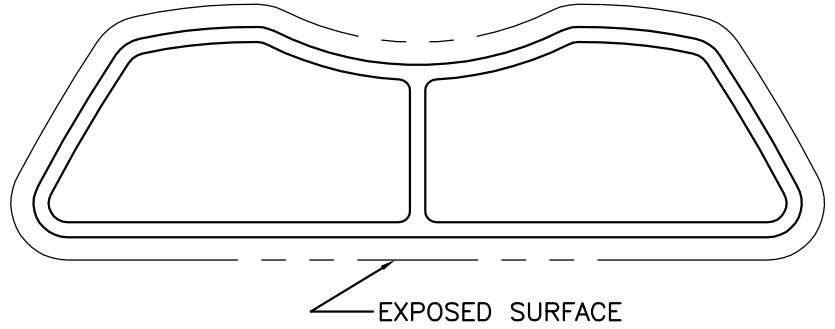

☞ **RADIUS 1.5 mm. ADDED 4 PLACES.
AS PER QUALITY MEETING.
ON DATED 10 SEPT. 2013.**

A = RADIUS 1.5 mm. (4 PLACES)



SYMBOL OF QUALITY
AN ISO 9001 COMPANY

JINDAL ALUMINIUM LTD.
BANGALORE-560073 (INDIA)

	NAME	DATE
DRAWN	J.P.KAUSHIK	23-08-2013
CHECKED		
APPROVED	S.S.GARG	25-08-2011
SCALE		1:1
AREA mm ²		496.848
PERIMETER mm.		234.985
WEIGHT kg/m		1.341
DRAWING No.	SECTION No.	
P-11129	-	
S3036	S3036	
27944	27944	

1. ALL DIMENSIONS ARE IN mm.
2. ROUND OFF ALL SHARP CORNERS WITH 0.40 mm.
3. TOLERANCES WILL BE AS PER, BS:EN-755-9 UNLESS OTHERWISE SPECIFIED

PARTY'S NAME	TEAM CONCEPTS PVT. LTD., BANGALORE
PARTY'S DRAWING No.	TKM RB-04
ALLOY & TEMPER	63400 WP
DESCRIPTION	MISC. TUBE