

P-9919-2
S2505
27948

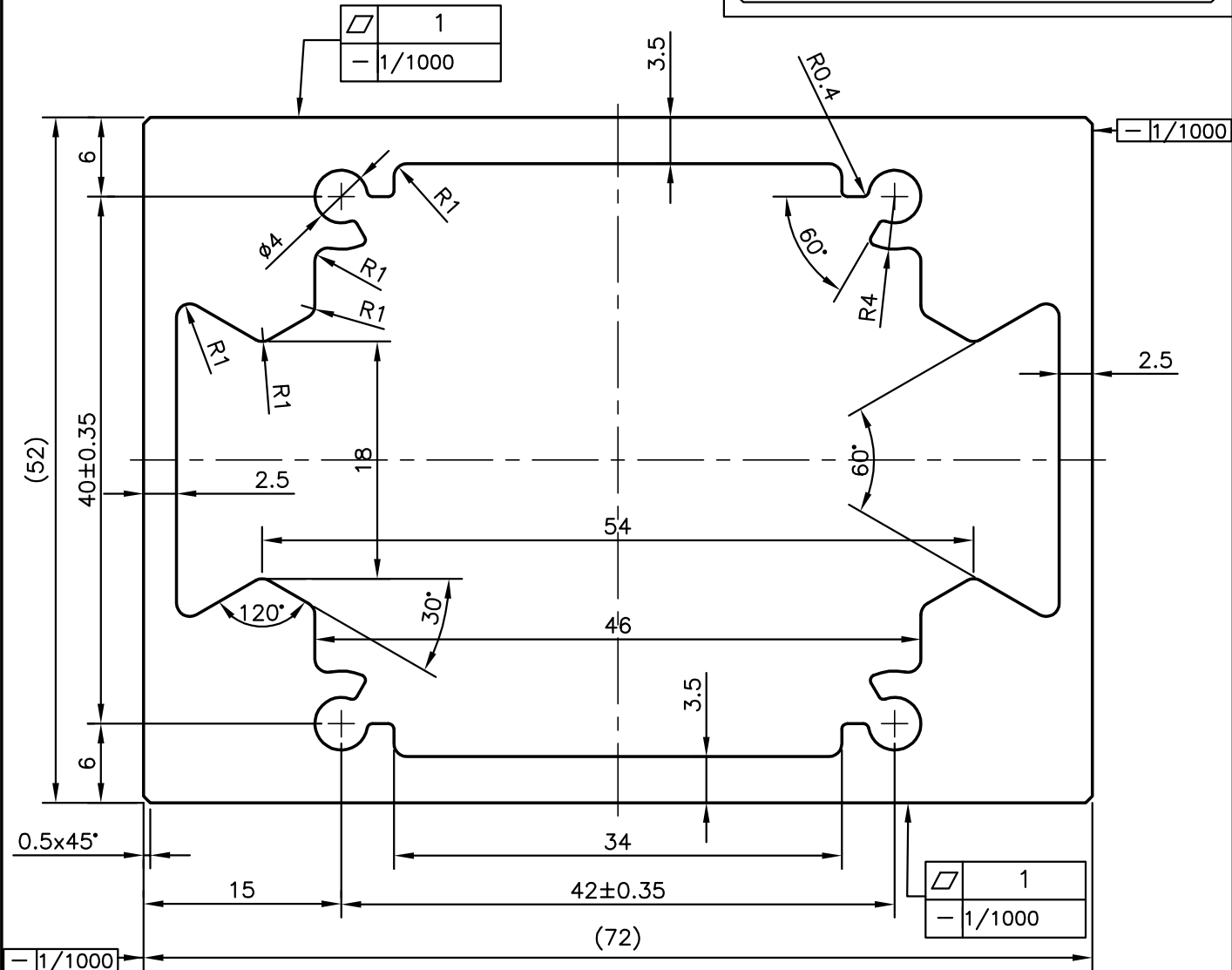
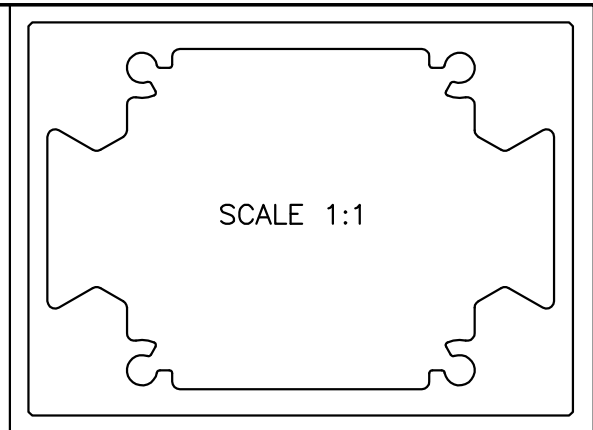

STRAIGHTNESS = 1.0 mm/1000 mm
 FLATNESS = 1.0 mm/1000 mm

 SYMBOL OF QUALITY AN ISO 9001 COMPANY	JINDAL ALUMINIUM LTD. BANGALORE-560073 (INDIA)	DRAWN	NAME	DATE
		CHECKED	RAGHAVENDRA	27-03-2010
1. ALL DIMENSIONS ARE IN mm. 2. ROUND OFF ALL SHARP CORNERS WITH 0.40 mm. 3. TOLERANCES WILL BE AS PER IS:6477-1983 UNLESS OTHERWISE SPECIFIED		APPROVED	S.S.GARG	30-03-2010
		SCALE		2:1
PARTY'S NAME BIESSE MANUFACTURING COMPANY PVT. LTD., BANGALORE		AREA	mm ²	1304.555
		PERIMETER	mm.	246.828
PARTY'S DRAWING No. GSK4550003		WEIGHT	kg/m	3.522
		DRAWING No.		SECTION No.
ALLOY & TEMPER 6063 T5		P-9919-2		-
		S2505		S2505
DESCRIPTION/END USE VACUUM DISTRIBUTOR - EXTRUSION		27948		27948