

P-10043-1
X1285
27956

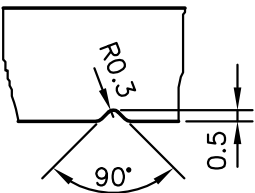

DETAILS OF 'V' GROOVE
SCALE 1:3

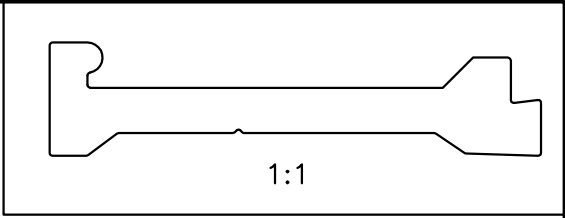
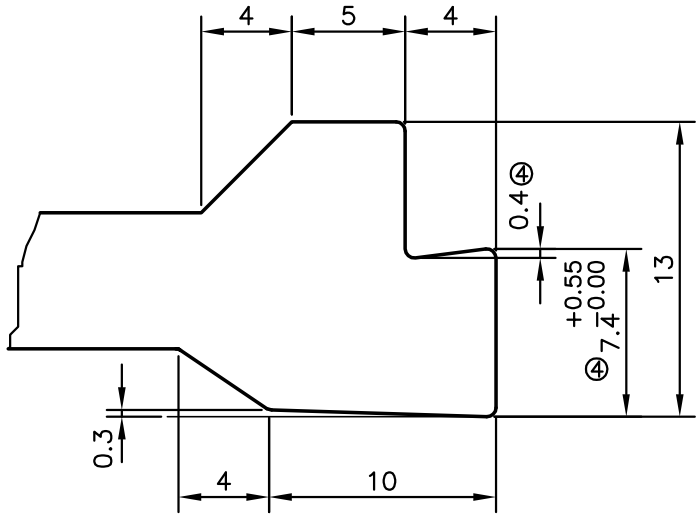

DETAIL "A"
SCALE 3:1

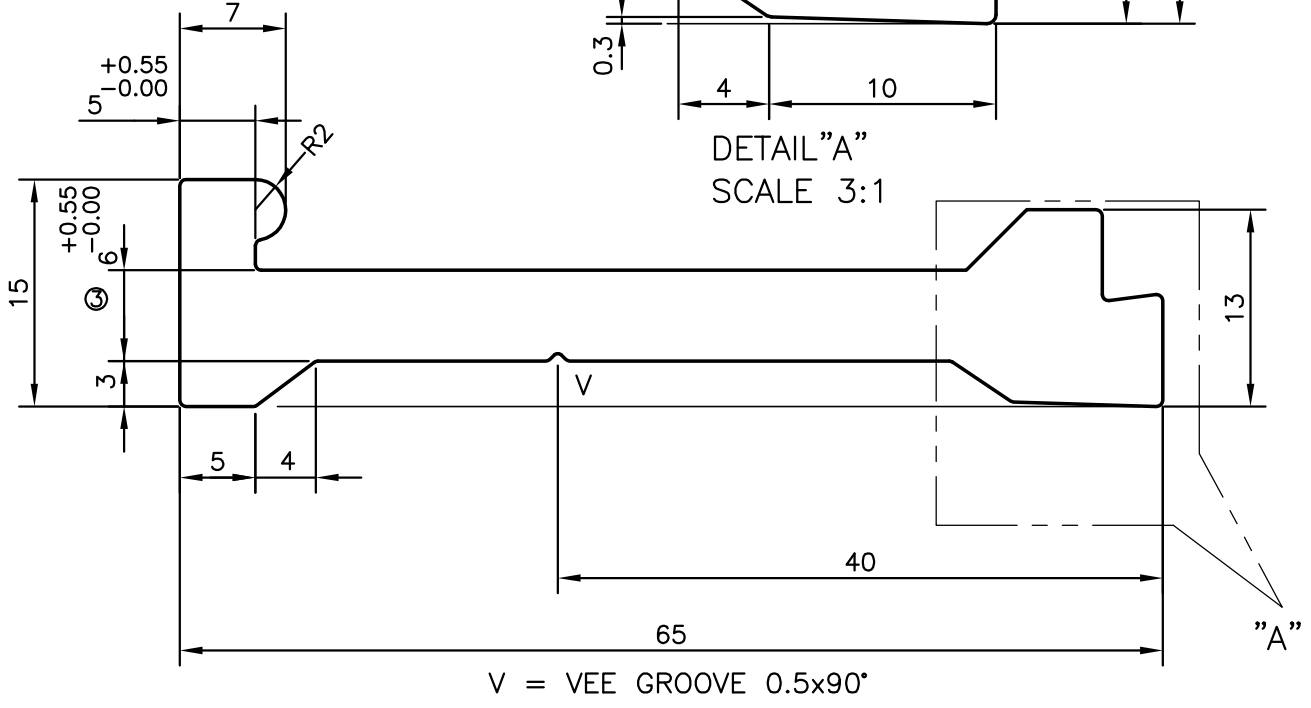

ISSUE-2 TOLERANCE ADDED ON THICKNESS

ISSUE-3 DIMENSIONS CHANGED FROM 5 mm TO 6 mm & 5 mm TO 7mm

WEIGHT ALSO CHANGED FROM 1.160 kg/M TO 1.352 kg/M

ISSUE-4 0.4 mm TAPER ADDED & DIMENSION CHANGED FROM 7.0 mm TO 7.4 mm

WEIGHT ALSO CHANGED FROM 1.352 kg/M TO 1.354 kg/M

 SYMBOL OF QUALITY AN ISO 9001 COMPANY	JINDAL ALUMINIUM LTD. BANGALORE-560073 (INDIA)	DRAWN J.P.KAUSHIK	NAME J.P.KAUSHIK	DATE 17-01-2011
		CHECKED APPROVED J.N. RAI	APPROVED J.N. RAI	DATE 15-02-2011
1. ALL DIMENSIONS ARE IN mm. 2. ROUND OFF ALL SHARP CORNERS WITH 0.40 mm. 3. TOLERANCES WILL BE AS PER IS:3965-1981 UNLESS OTHERWISE SPECIFIED		SCALE 2:1		
		AREA mm ² 501.59		
PARTY'S NAME JANARDAN INDUSTRIES, PUNE		PERIMETER mm. 169.176		
		WEIGHT kg/m 1.354		
PARTY'S DRAWING No. AS PER SKETCH		DRAWING No. P-10043-1		
		SECTION No. -		
ALLOY & TEMPER 6061 T6		X1285 X1285(ISSUE-4)		
		27956 27956		
DESCRIPTION I SECTION				