

P-10048-1

X1290

27964

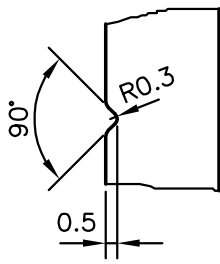

DETAILS OF 'V' GROOVE

SCALE 1:3

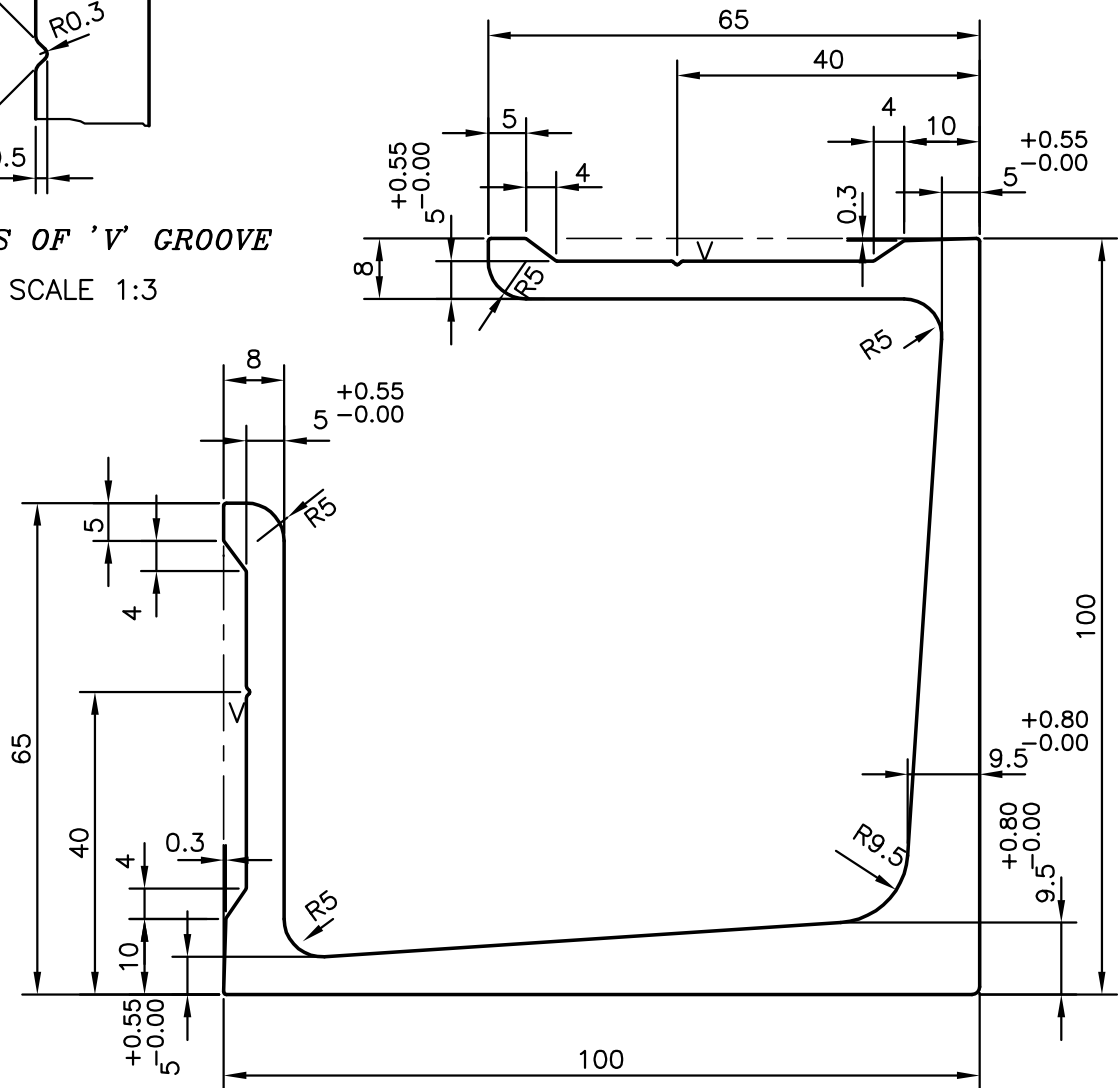

ISSUE-2 TOLERANCE ADDED ON THICKNESS

V = VEE GROOVE 0.5x90° (2)



SYMBOL OF QUALITY
AN ISO 9001 COMPANY

JINDAL ALUMINIUM LTD.
BANGALORE-560073 (INDIA)

	NAME	DATE
DRAWN	J.P.KAUSHIK	19-06-2010
CHECKED		
APPROVED		

1. ALL DIMENSIONS ARE IN mm.
2. ROUND OFF ALL SHARP CORNERS WITH 0.40 mm.
3. TOLERANCES WILL BE AS PER IS:3965-1981 UNLESS OTHERWISE SPECIFIED

SCALE	1:1
AREA mm ²	2082.78
PERIMETER mm.	621.825
WEIGHT kg/m	5.624

PARTY'S NAME JANARDAN INDUSTRIES, PUNE

PARTY'S DRAWING No. AS PER SKETCH

ALLOY & TEMPER 6061 T6

DESCRIPTION G100 W/O SUPPORT

DRAWING No.	SECTION No.
P-10048-1	-
X1290	X1290(ISSUE-2)
27964	27964