

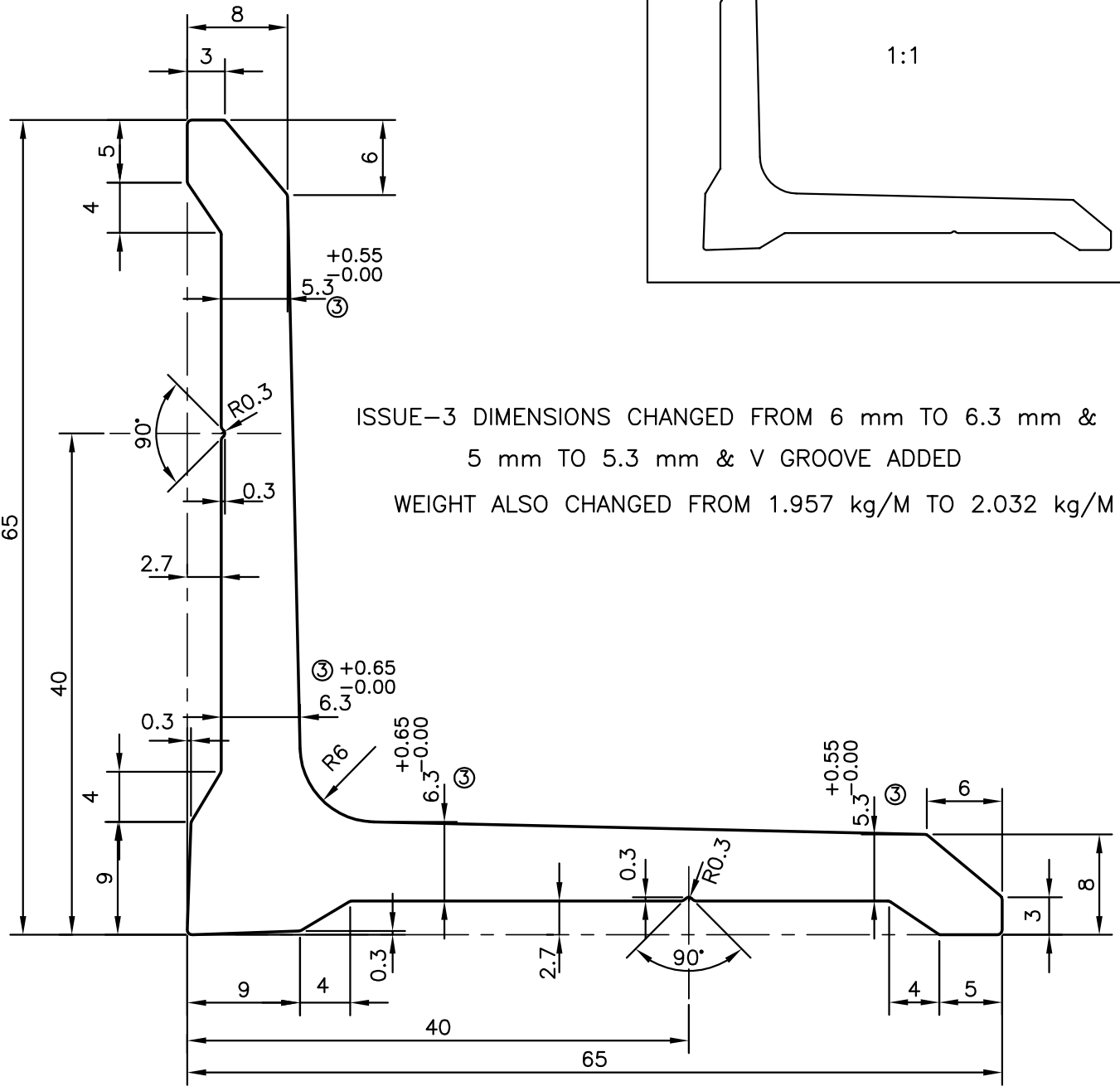

P-10044-1
X1286
27966

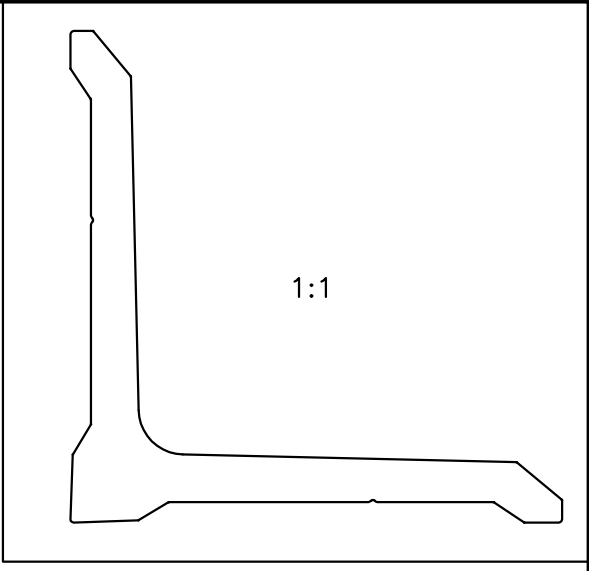

ISSUE-3 DIMENSIONS CHANGED FROM 6 mm TO 6.3 mm &  
 5 mm TO 5.3 mm & V GROOVE ADDED  
 WEIGHT ALSO CHANGED FROM 1.957 kg/M TO 2.032 kg/M

ISSUE-2 TOLERANCE ADDED ON THICKNESS

 SYMBOL OF QUALITY AN ISO 9001 COMPANY	<b>JINDAL ALUMINIUM LTD.</b> BANGALORE-560073 (INDIA)	NAME		DATE
		DRAWN	J.P.KAUSHIK	23-08-2010
1. ALL DIMENSIONS ARE IN mm. 2. ROUND OFF ALL SHARP CORNERS WITH 0.40 mm. 3. TOLERANCES WILL BE AS PER IS:3965-1981 UNLESS OTHERWISE SPECIFIED		CHECKED		
		APPROVED		S.S.GARG
PARTY'S NAME JANARDAN INDUSTRIES, PUNE		SCALE		2:1
		AREA mm <sup>2</sup>		752.628
PARTY'S DRAWING No. AS PER SKETCH		PERIMETER mm.		251.803
		WEIGHT kg/m		2.032
ALLOY & TEMPER 6061 T6		DRAWING No.		P-10044-1
		SECTION No.		-
DESCRIPTION ANGLE 65		X1286		X1286(ISSUE-3)
		27966		27966