

P-10067-1

S2558

27970

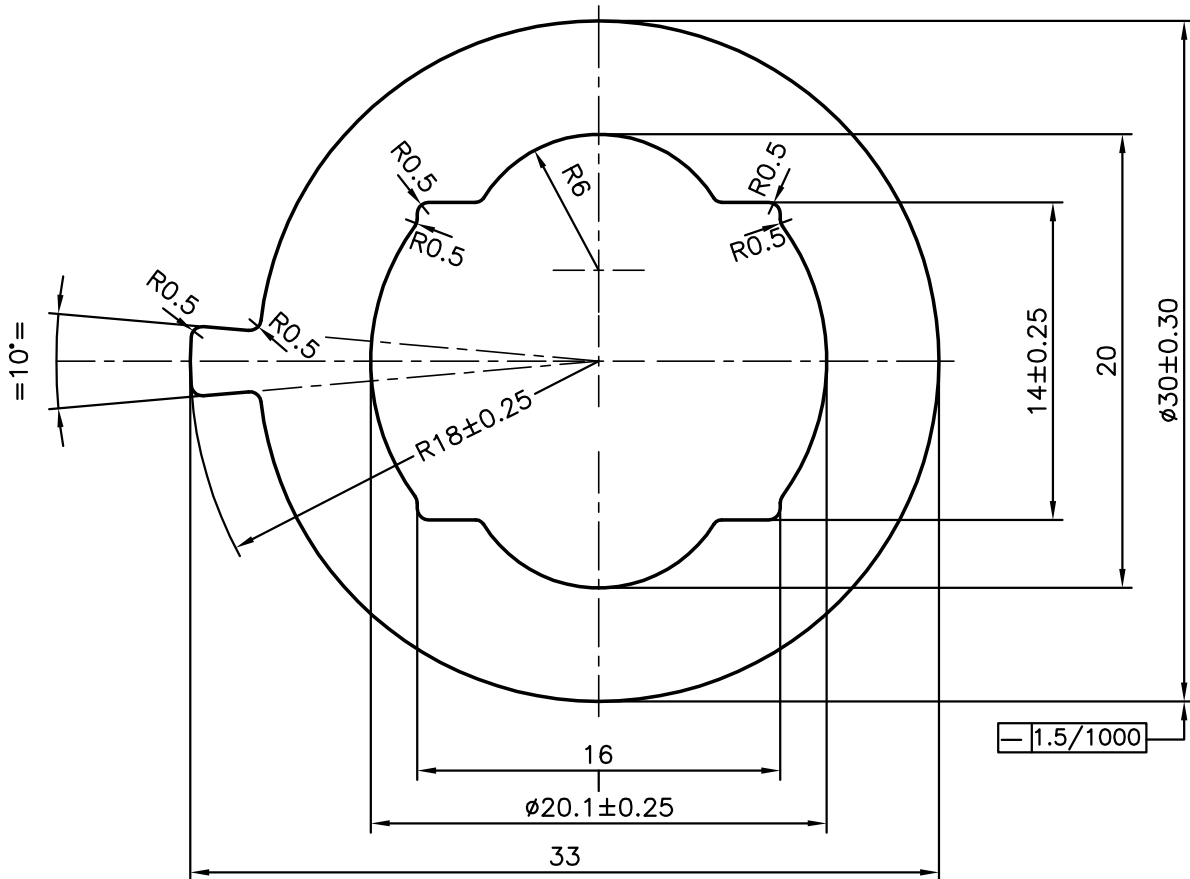
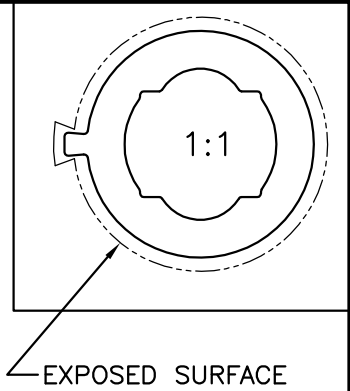

STRAIGHTNESS (BEND & TWIST) :- 1.5mm/M



SYMBOL OF QUALITY  
AN ISO 9001 COMPANY

**JINDAL ALUMINIUM LTD.**  
BANGALORE-560073 (INDIA)

	NAME	DATE
DRAWN	J.P.KAUSHIK	08-06-2010
CHECKED		
APPROVED	S.S.GARG	18-06-2010
SCALE		3:1
AREA mm <sup>2</sup>		413.441
PERIMETER mm.		99.915
WEIGHT kg/m		1.116
DRAWING No.	SECTION No.	
P-10067-1	-	
S2558	S2558	
27970	27970	

1. ALL DIMENSIONS ARE IN mm.
2. ROUND OFF ALL SHARP CORNERS WITH 0.40 mm.
3. TOLERANCES WILL BE AS PER IS:6477-1983 UNLESS OTHERWISE SPECIFIED

PARTY'S NAME	BIESSE MANUFACTURING CO PVT. LTD., BANGALORE
PARTY'S DRAWING No.	50-14-L0215
ALLOY & TEMPER	6060 T5
DESCRIPTION	MISC. SECTION