

P-9843

S2722

27983

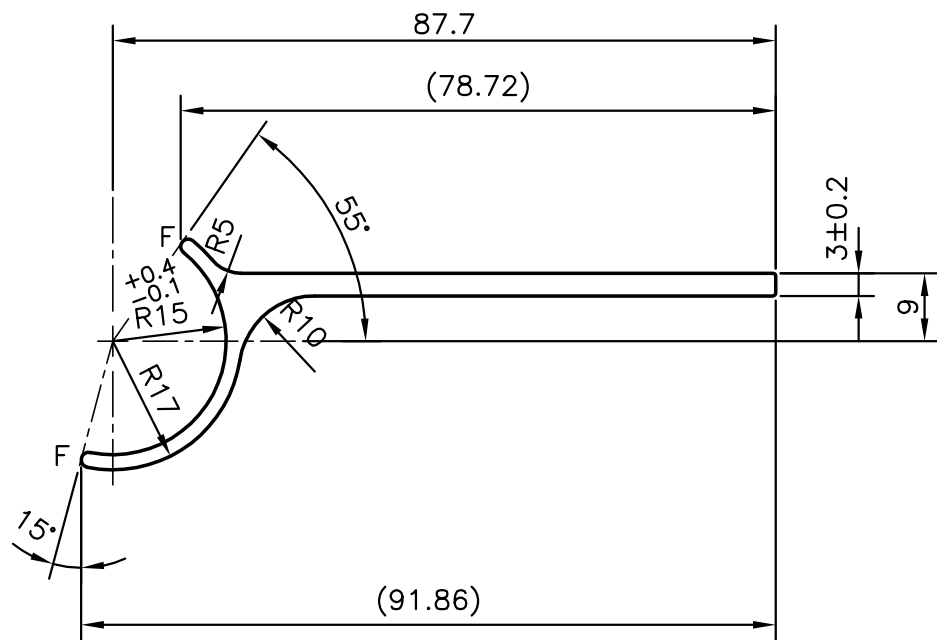

F = FULL RADIUS (2)



SYMBOL OF QUALITY
AN ISO 9001 COMPANY

JINDAL ALUMINIUM LTD.
BANGALORE-560073 (INDIA)

	NAME	DATE
DRAWN	J.P.KAUSHIK	23-02-2010
CHECKED		
APPROVED	S.S.GARG	11-10-2010
SCALE		1:1
AREA mm ²		327.93
PERIMETER mm.		230.398
WEIGHT kg/m		0.885
DRAWING No.	SECTION No.	
P-9843	-	
S2722	S2722	
27983	27983	

1. ALL DIMENSIONS ARE IN mm.
2. ROUND OFF ALL SHARP CORNERS WITH 0.40 mm.
3. TOLERANCES WILL BE AS PER IS:3965-1981 UNLESS OTHERWISE SPECIFIED

PARTY'S NAME	WONJIN AUTOPARTS PVT. LTD., MARAIMALAI NAGAR
PARTY'S DRAWING No.	PL-F843MD9AA01
ALLOY & TEMPER	6005 T6
DESCRIPTION	BRACKET MOUNTING SECTION