

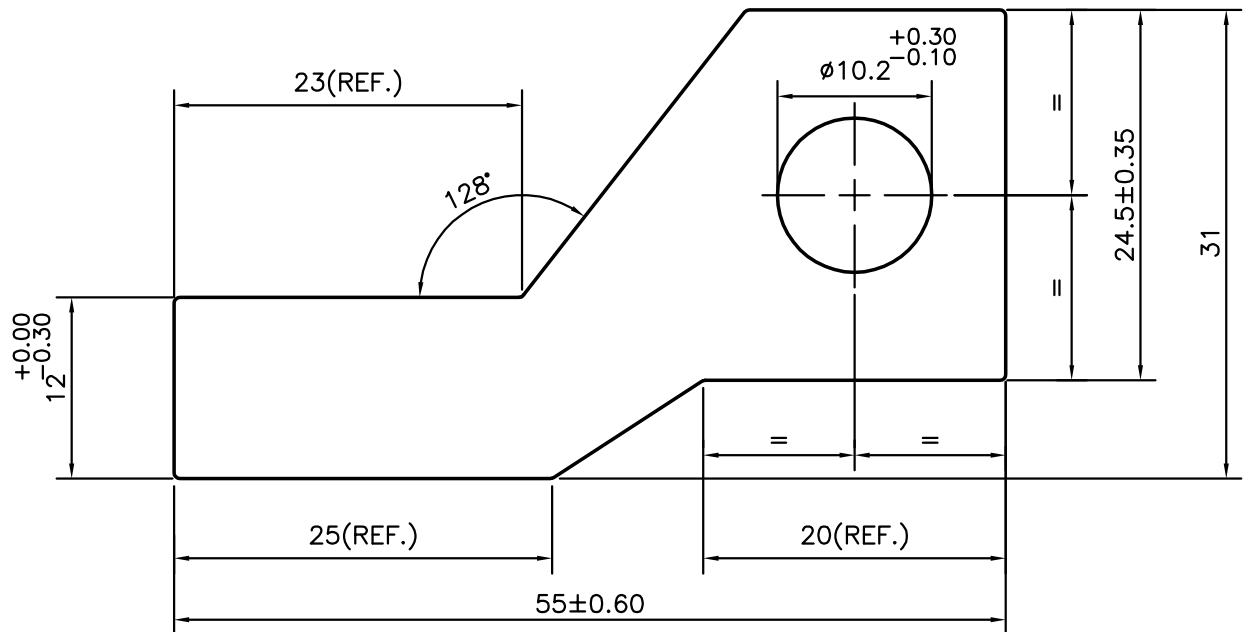

P-10695-2

S2829

27997

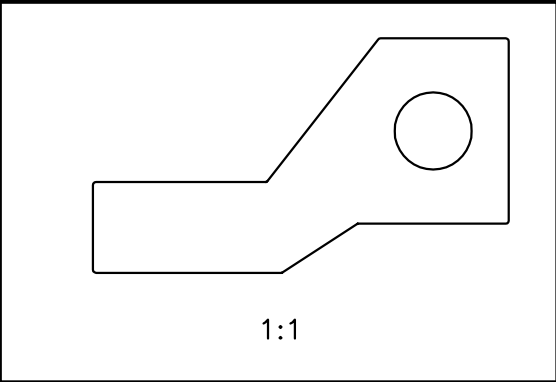

 SYMBOL OF QUALITY AN ISO 9001 COMPANY	JINDAL ALUMINIUM LTD. BANGALORE-560073 (INDIA)	NAME		DATE
		DRAWN	J.P.KAUSHIK	19-01-2011
1. ALL DIMENSIONS ARE IN mm. 2. ROUND OFF ALL SHARP CORNERS WITH 0.40 mm. 3. TOLERANCES WILL BE AS PER, IS:6477-1983 UNLESS OTHERWISE SPECIFIED		CHECKED		
		APPROVED		S.S.GARG
PARTY'S NAME		SCALE		2:1
		AREA mm ²		882.628
PARTY'S DRAWING No.		PERIMETER mm.		156.94
		WEIGHT kg/m		2.383
ALLOY & TEMPER		DRAWING No.		SECTION No.
		P-10695-2		-
DESCRIPTION		S2829		S2829
		27997		27997
MISC. SECTION				