

P-10822

S2868

28012

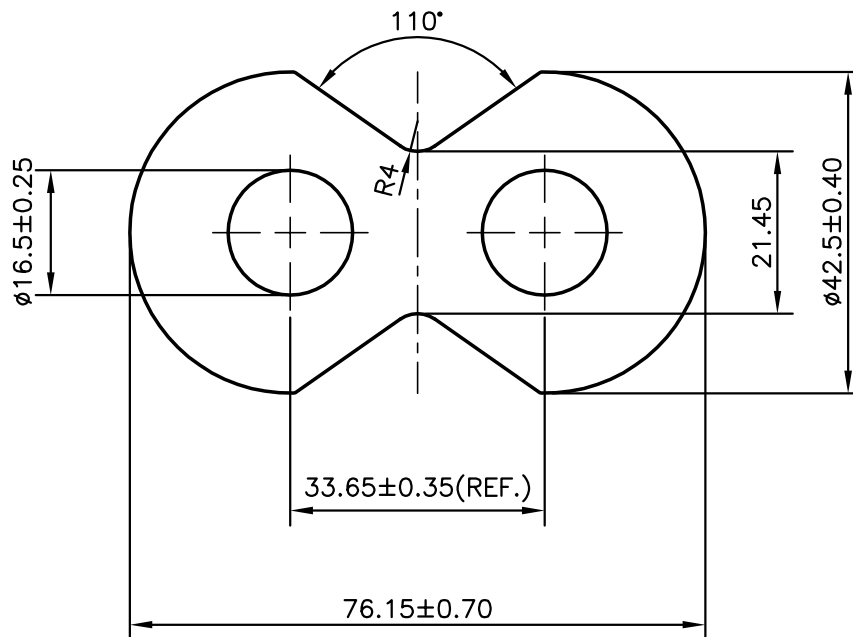

SYMBOL OF QUALITY  
AN ISO 9001 COMPANY

**JINDAL ALUMINIUM LTD.**  
BANGALORE-560073 (INDIA)

	NAME	DATE
DRAWN	J.P.KAUSHIK	05-03-2011
CHECKED		
APPROVED	S.S.GARG	11-03-2011

1. ALL DIMENSIONS ARE IN mm.
2. ROUND OFF ALL SHARP CORNERS WITH 0.40 mm.
3. TOLERANCES WILL BE AS PER, IS:6477-1983 UNLESS OTHERWISE SPECIFIED

SCALE	1:1
AREA mm <sup>2</sup>	2052.218
PERIMETER mm.	213.739
WEIGHT kg/m	5.541

PARTY'S NAME GEARED HYDROPOWER PVT. LTD., BELGAUM

DRAWING No. SECTION No.

PARTY'S DRAWING No. 102 000 030- m/c

P-10822

-

ALLOY & TEMPER HE30 WP

S2868

S2868

DESCRIPTION

MISC. SECTION

28012

28012