

P-10898-1

S2907

28021

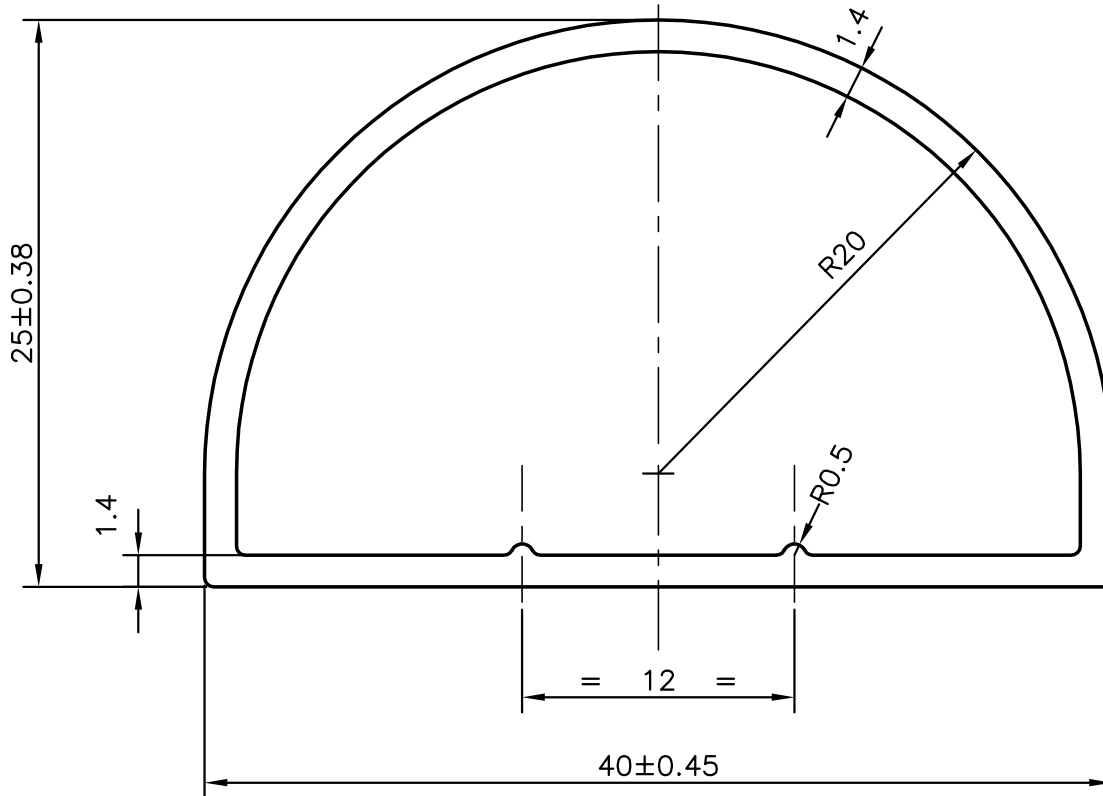
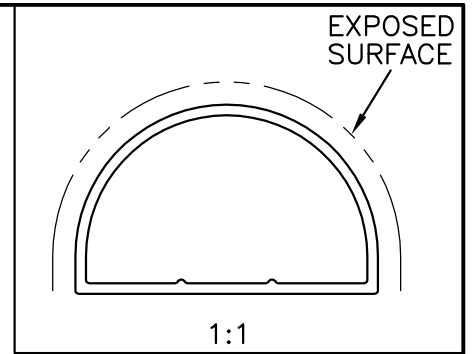

SYMBOL OF QUALITY  
AN ISO 9001 COMPANY

**JINDAL ALUMINIUM LTD.**  
BANGALORE-560073 (INDIA)

	NAME	DATE
DRAWN	J.PKAUSHIK	23-04-2011
CHECKED		
APPROVED	S.S.GARG	04-05-2011
SCALE		3:1
AREA mm <sup>2</sup>		151.811
PERIMETER mm.		112.488
WEIGHT kg/m		0.410
DRAWING No.	SECTION No.	
P-10898-1	-	
S2907	S2907	
28021	28021	

1. ALL DIMENSIONS ARE IN mm.
2. ROUND OFF ALL SHARP CORNERS WITH 0.40 mm.
3. TOLERANCES WILL BE AS PER IS:6477-1983 UNLESS OTHERWISE SPECIFIED

PARTY'S NAME	TEAM CONCEPTS PVT. LTD., BANGALORE
PARTY'S DRAWING No.	M&M RC-SIDE
ALLOY & TEMPER	6063 T5
DESCRIPTION	MISC. TUBE-SIDE