

P-12928

28026

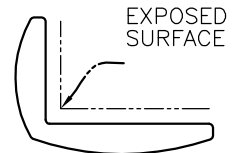

SCALE: - 1:1

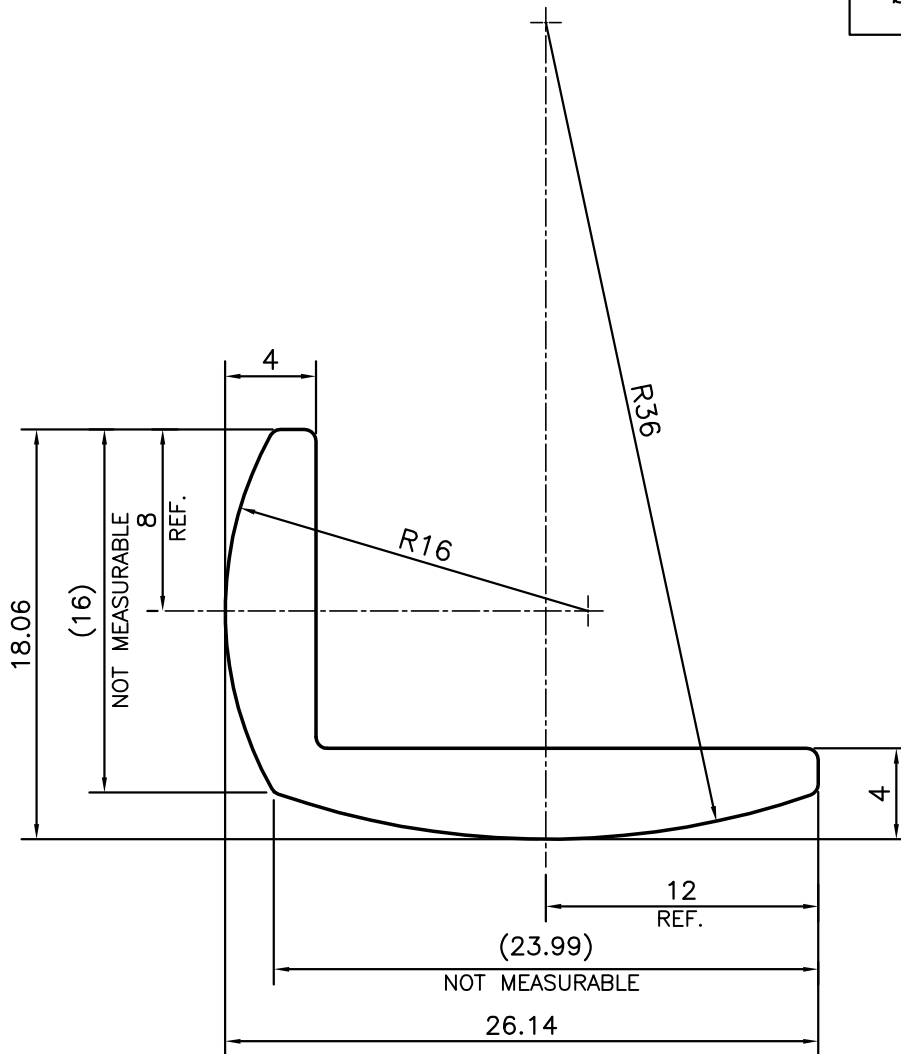

SYMBOL OF QUALITY
AN ISO 9001 COMPANY

JINDAL ALUMINIUM LTD.
BANGALORE-560073 (INDIA)

	NAME	DATE
DRAWN	PARVESH	26-07-2013
CHECKED		
APPROVED	S.S.GARG	30-08-2013
SCALE		3:1
AREA mm ²		128.911
PERIMETER mm.		80.411
WEIGHT kg/m		0.348

1. ALL DIMENSIONS ARE IN mm.
2. ROUND OFF ALL SHARP CORNERS WITH 0.50 mm.
3. TOLERANCES WILL BE AS PER BS:EN-12020-2 , UNLESS OTHERWISE SPECIFIED

PARTY'S NAME	TUBE AND FITTING AFRICA MIDDLE EAST, GERMANY	DRAWING No.	P-12928	SECTION No.	-
PARTY'S DRAWING No.	PROFILE 6		28026		28026
ALLOY & TEMPER	6060 T66				
DESCRIPTION	INDUSTRIAL SECTION				