

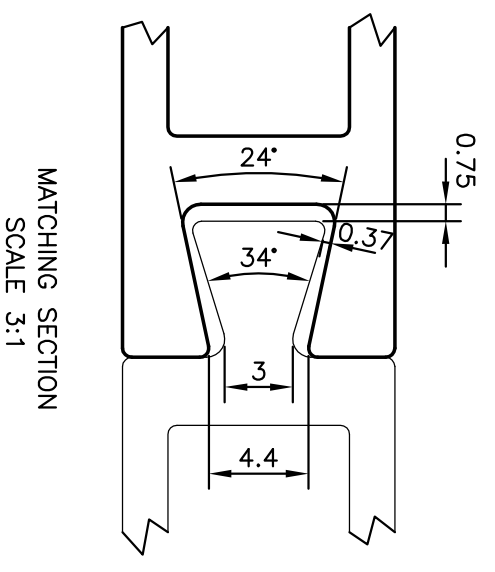

ISSUE (2) :-
DIMENSION CHANGED FROM :-
64.00 TO 63.35
6.00 TO 6.75 AND
ANGLE ALSO CHANGED FROM
28° TO 24° & 34° & WEIGHT ALSO
CHANGED FROM 2.418 kg/M TO 2.426 kg/M

ISSUE (3) :-
DIMENSION CHANGED FROM:-
1. 63.90 mm. TO 62.40 mm.
2. 63.35 mm. TO 61.85 mm.
3. THICKNESS 2.0 mm. TO 3.5 mm. (4 PLACES).
4. WEIGHT ALSO CHANGED FROM 2.426 kg/m. TO 2.896 kg/m.



MATCHING SECTION
SCALE 3:1

 SYMBOL OF QUALITY AN ISO 9001 COMPANY		JINDAL ALUMINIUM LTD. BANGALORE-560073 (INDIA)		DRAWN	NAME	DATE
				CHECKED		
1. ALL DIMENSIONS ARE IN mm. 2. ROUND OFF ALL SHARP CORNERS WITH 0.40 mm. 3. TOLERANCES WILL BE AS PER IS:6477-1983 UNLESS OTHERWISE SPECIFIED		APPROVED	S.S.GARG	28-02-2013		
PARTY'S NAME SAHIB TRADING CO., MOHALI		SCALE	1:1			
PARTY'S DRAWING No. AS PER DRAWING		AREA	mm ² 1072.523			
ALLOY & TEMPER 6063 T6		PERIMETER	mm. 440.542			
DESCRIPTION HEATING PLATEN SECTION		WEIGHT	kg/m 2.896			
		DRAWING No.	SECTION No.			
P-10983		-				
S2939		S2939-ISSUE-3				
28028		28028				