

P-11534-1

S3214

28044

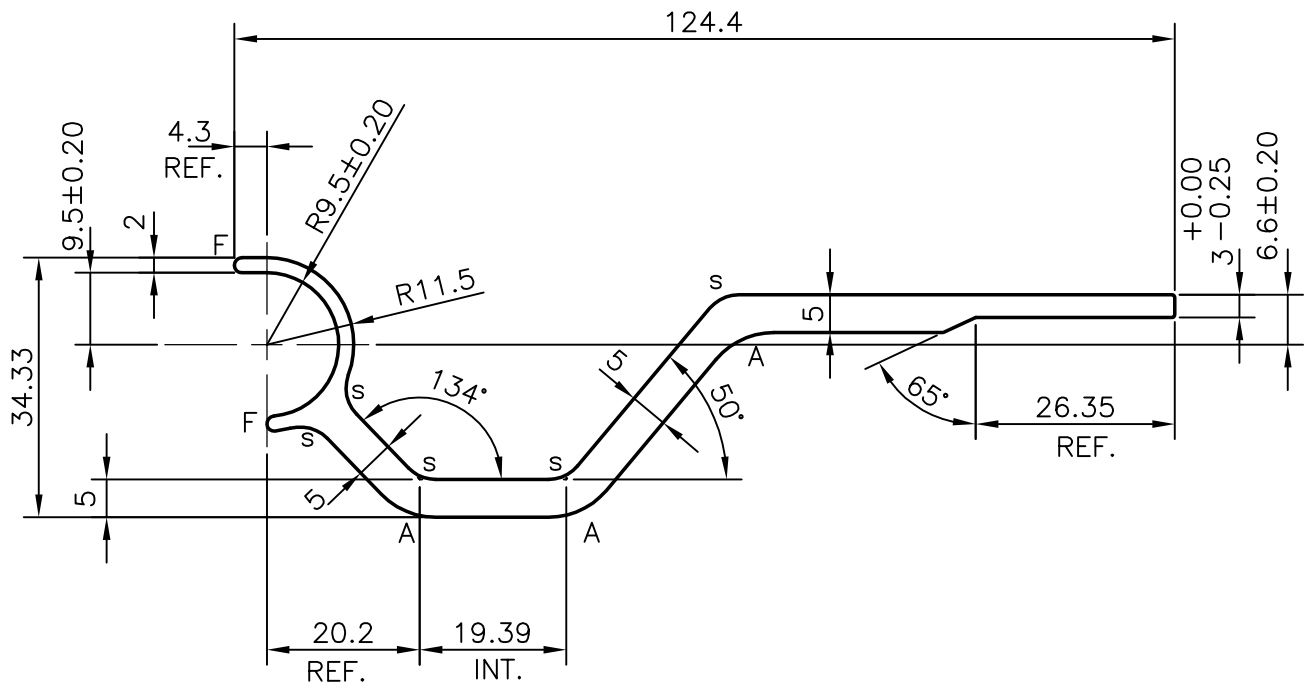

S = RADIUS 5 mm. (5 PLACES)

A = RADIUS 10 mm. (3 PLACES)

F = FULL RADIUS (2 PLACES)



SYMBOL OF QUALITY
AN ISO 9001 COMPANY

JINDAL ALUMINIUM LTD.
BANGALORE-560073 (INDIA)

	NAME	DATE
DRAWN	PARVESH	17-02-2012
CHECKED		
APPROVED	S.S.GARG	09-03-2012
SCALE		1:1
AREA mm ²		663.187
PERIMETER mm.		328.751
WEIGHT kg/m		1.791
DRAWING No.	SECTION No.	
P-11534-1	-	
S3214	S3214	
28044	28044	

1. ALL DIMENSIONS ARE IN mm.
2. ROUND OFF ALL SHARP CORNERS WITH 0.50 mm.
3. TOLERANCES WILL BE AS PER IS:3965-1981, UNLESS OTHERWISE SPECIFIED

PARTY'S NAME	WONJIN AUTOPARTS INDIA PVT. LTD. MARAMALAI NAGAR
PARTY'S DRAWING No.	PL F844 MD9AA01 000
ALLOY & TEMPER	6005 T5
DESCRIPTION	BRKT - (C) COND. MTG