

P-11243

S3074

28055

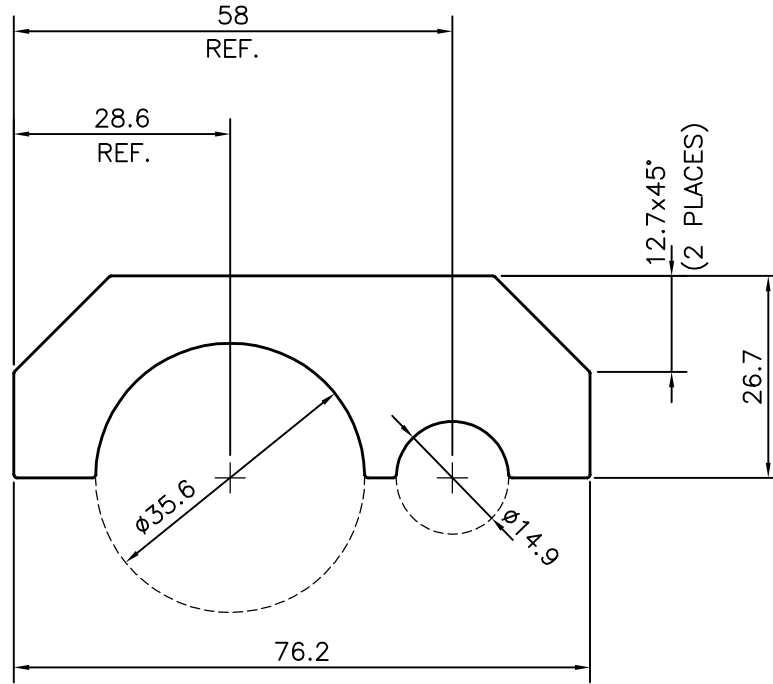

SYMBOL OF QUALITY
AN ISO 9001 COMPANY

JINDAL ALUMINIUM LTD.
BANGALORE-560073 (INDIA)

	NAME	DATE
DRAWN	PARVESH	29-09-2011
CHECKED		
APPROVED	S.S.GARG	25-10-2011
SCALE		1:1
AREA mm ²		1288.164
PERIMETER mm.		218.676
WEIGHT kg/m		3.478
DRAWING No.	SECTION No.	
P-11243	-	
S3074	S3074	
28055	28055	

1. ALL DIMENSIONS ARE IN mm.
2. ROUND OFF ALL SHARP CORNERS WITH 0.40 mm.
3. TOLERANCES WILL BE AS PER, BS:EN-755-9 UNLESS OTHERWISE SPECIFIED

PARTY'S NAME	AUTOCRAT ENGINEERS, BANGALORE
PARTY'S DRAWING No.	759M070B
ALLOY & TEMPER	6351 T6
DESCRIPTION	BLOCK TRANSFER TOP