

P-11307-1

S3111

28062

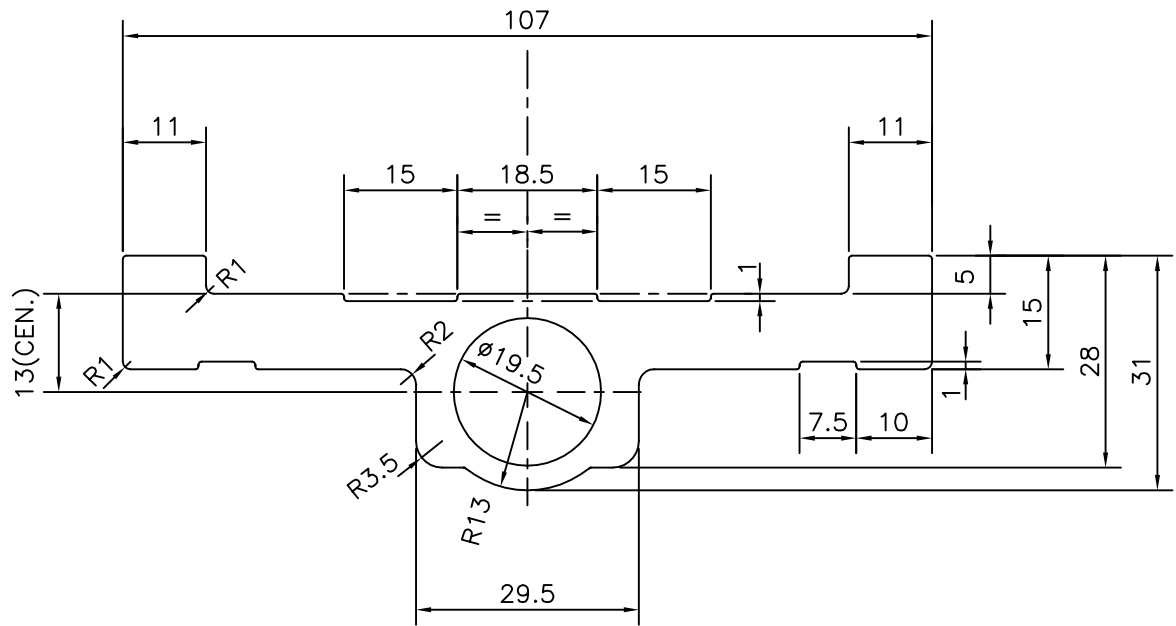

SYMBOL OF QUALITY
AN ISO 9001 COMPANY

JINDAL ALUMINIUM LTD.
BANGALORE-560073 (INDIA)

	NAME	DATE
DRAWN	J.P.KAUSHIK	11-11-2011
CHECKED		
APPROVED	S.S.GARG	25-11-2011
SCALE		1:1
AREA mm ²		1250.256
PERIMETER mm.		279.514
WEIGHT kg/m		3.376
DRAWING No.	SECTION No.	
P-11307-1	-	
S3111	S3111	
28062	28062	

1. ALL DIMENSIONS ARE IN mm.
2. ROUND OFF ALL SHARP CORNERS WITH 0.40 mm.
3. TOLERANCES WILL BE AS PER, BS:EN-755-9 UNLESS OTHERWISE SPECIFIED

PARTY'S NAME	COLTON INDUSTRIES, BANGALORE
PARTY'S DRAWING No.	AS PER DRAWING
ALLOY & TEMPER	63400 WP
DESCRIPTION	MISC. SECTION