

P-11766-2

S3289

28065

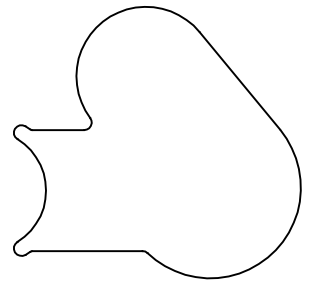

SCALE :- 1:1

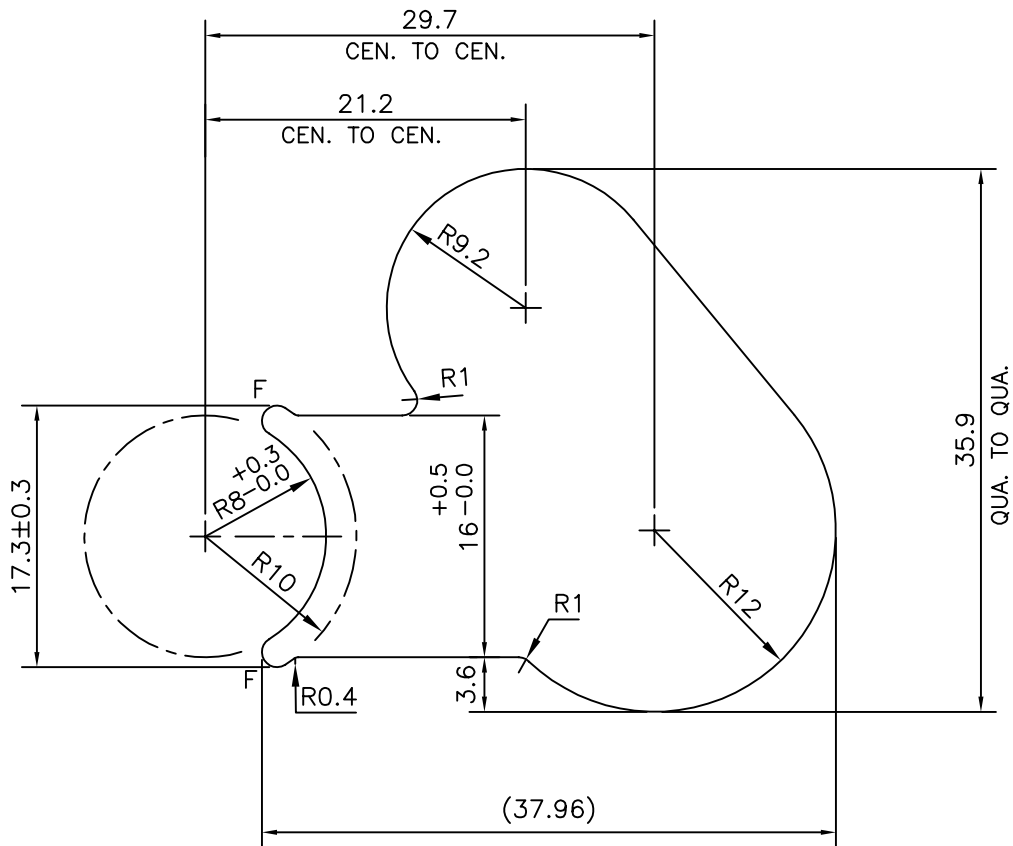

F = FULL RADIUS (2 PLACES)



SYMBOL OF QUALITY  
AN ISO 9001 COMPANY

**JINDAL ALUMINIUM LTD.**  
BANGALORE-560073 (INDIA)

	NAME	DATE
DRAWN	PARVESH	30-05-2012
CHECKED		
APPROVED	J.N.RAI	01-06-2012
SCALE		2:1
AREA mm <sup>2</sup>		896.551
PERIMETER mm.		130.495
WEIGHT kg/m		2.421
DRAWING No.	SECTION No.	
P-11766-2	-	
S3289	S3289	
28065	28065	

1. ALL DIMENSIONS ARE IN mm.
2. ROUND OFF ALL SHARP CORNERS WITH 0.40 mm.
3. TOLERANCES WILL BE AS PER IS:3965-1981, UNLESS OTHERWISE SPECIFIED

PARTY'S NAME	PRECISION COMPONENTS INDIA, MOHALI
PARTY'S DRAWING No.	924X4 3VDIA-N-CONN O-RING IN
ALLOY & TEMPER	6063 T6
DESCRIPTION	AUTOMOBILE SECTION