

P-11395-2

S3164

28072

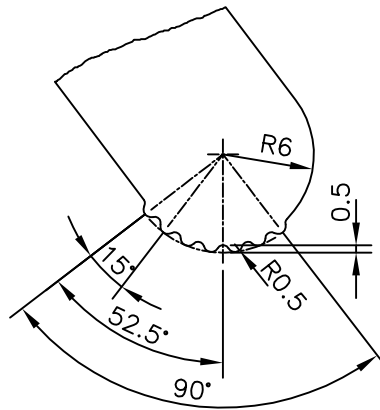
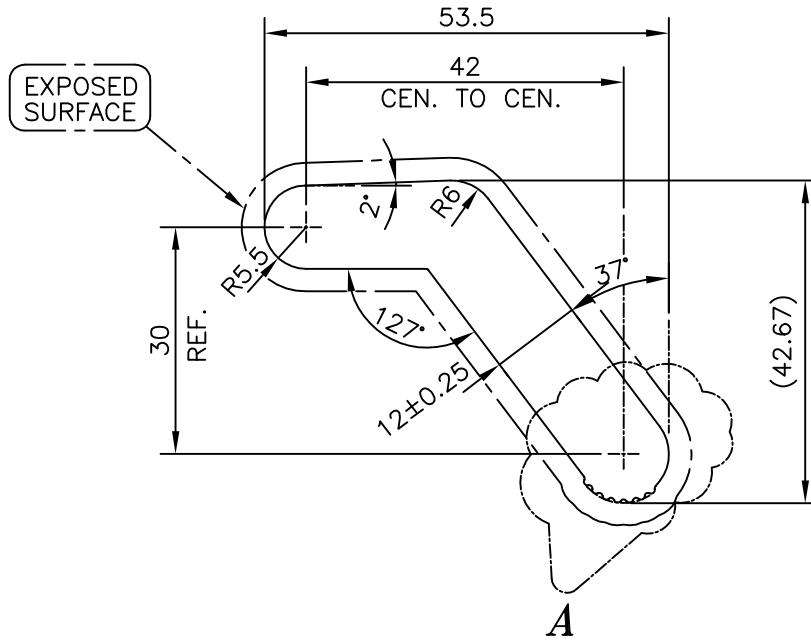

DETAIL OF "A"
SCALE 2:1



SYMBOL OF QUALITY
AN ISO 9001 COMPANY

JINDAL ALUMINIUM LTD.
BANGALORE-560073 (INDIA)

	NAME	DATE
DRAWN	PARVESH	21-01-2012
CHECKED		
APPROVED	S.S.GARG	25-01-2012
SCALE		1:1
AREA mm ²		778.573
PERIMETER mm.		153.047
WEIGHT kg/m		2.102
DRAWING No.	SECTION No.	
P-11395-2	-	
S3164	S3164	
28072	28072	

1. ALL DIMENSIONS ARE IN mm. 2. ROUND OFF ALL SHARP CORNERS WITH 0.40 mm. 3. TOLERANCES WILL BE AS PER IS:3965-1981, UNLESS OTHERWISE SPECIFIED	
PARTY'S NAME	LEECOS MANUFACTURING TECHNOLOGY (I) PVT. LTD., CHENNAI
PARTY'S DRAWING No.	8203202 (LATCH-1)
ALLOY & TEMPER	6005 T6
DESCRIPTION	LATCH SECTION