

P-11396-2

S3165

28073

EXPOSED SURFACE

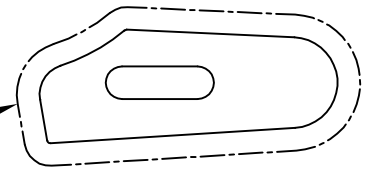

SCALE :- 1:1

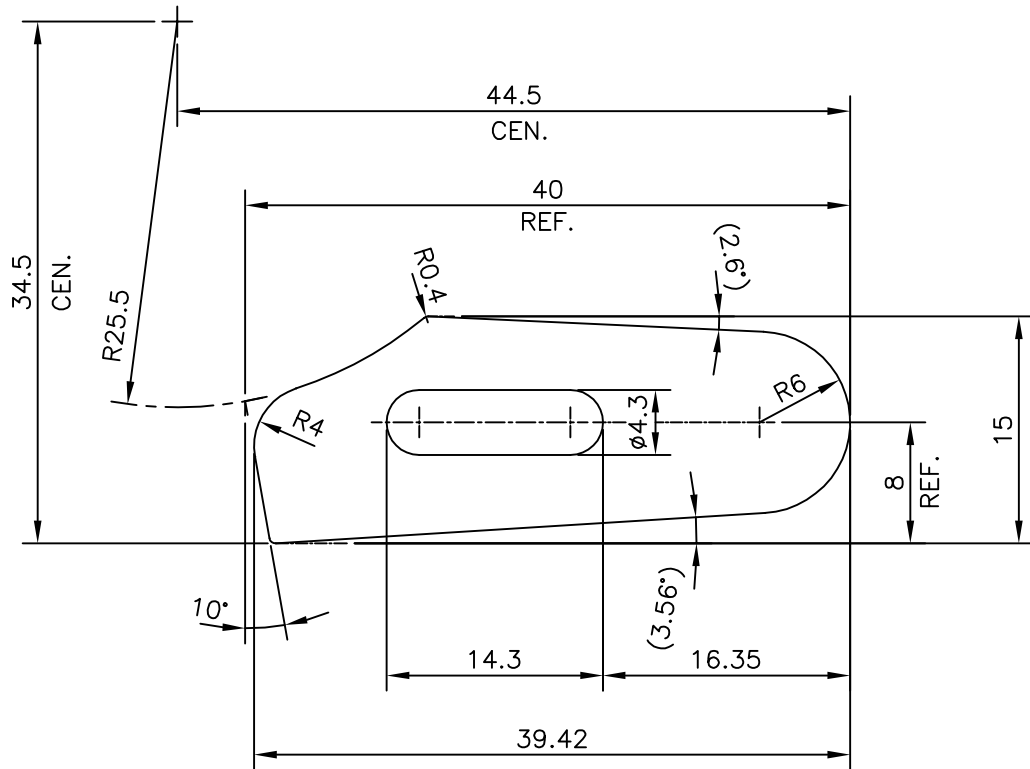

SYMBOL OF QUALITY
AN ISO 9001 COMPANY

JINDAL ALUMINIUM LTD.
BANGALORE-560073 (INDIA)

	NAME	DATE
DRAWN	PARVESH	29-12-2011
CHECKED		
APPROVED	S.S.GARG	25-01-2012
SCALE		2:1
AREA mm ²		414.73
PERIMETER mm.		94.65
WEIGHT kg/m		1.12
DRAWING No.	SECTION No.	
P-11396-2	-	
S3165	S3165	
28073	28073	

1. ALL DIMENSIONS ARE IN mm.
2. ROUND OFF ALL SHARP CORNERS WITH 0.40 mm.
3. TOLERANCES WILL BE AS PER IS:6477-1983, UNLESS OTHERWISE SPECIFIED

PARTY'S NAME	LEECOS MANUFACTURING TECHNOLOGY (I) PVT. LTD., CHENNAI
PARTY'S DRAWING No.	8203203 (LATCH 2)
ALLOY & TEMPER	6005 T6
DESCRIPTION	LATCH SECTION