

P-11767-2

S3290

28074

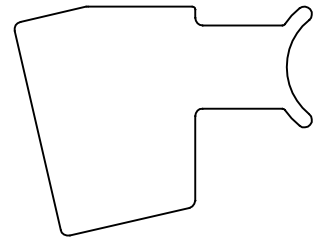

SCALE :- 1:1

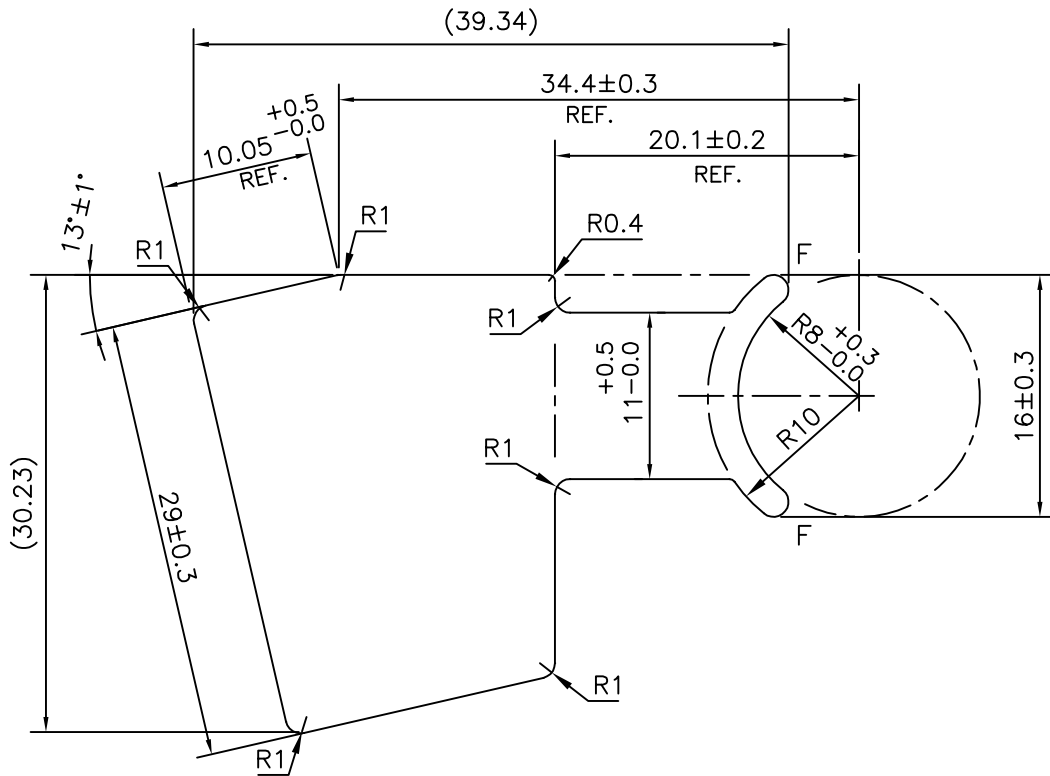

F = FULL RADIUS (2 PLACES)



SYMBOL OF QUALITY  
AN ISO 9001 COMPANY

**JINDAL ALUMINIUM LTD.**  
BANGALORE-560073 (INDIA)

|                      | NAME        | DATE       |
|----------------------|-------------|------------|
| DRAWN                | PARVESH     | 30-05-2012 |
| CHECKED              |             |            |
| APPROVED             | J.N.RAI     | 01-06-2012 |
| SCALE                |             | 2:1        |
| AREA mm <sup>2</sup> |             | 748.38     |
| PERIMETER mm.        |             | 134.85     |
| WEIGHT kg/m          |             | 2.021      |
| DRAWING No.          | SECTION No. |            |
| P-11767-2            | -           |            |
| S3290                | S3290       |            |
| 28074                | 28074       |            |
|                      |             |            |
|                      |             |            |

1. ALL DIMENSIONS ARE IN mm.
2. ROUND OFF ALL SHARP CORNERS WITH 0.40 mm.
3. TOLERANCES WILL BE AS PER IS:3965-1981, UNLESS OTHERWISE SPECIFIED

|                     |                                    |
|---------------------|------------------------------------|
| PARTY'S NAME        | PRECISION COMPONENTS INDIA, MOHALI |
| PARTY'S DRAWING No. | 92484 3VAIA-N-CONN O-RING OUT      |
| ALLOY & TEMPER      | 6063 T6                            |
| DESCRIPTION         | AUTOMOBILE SECTION                 |