

P-12194-1  
S3705  
28083

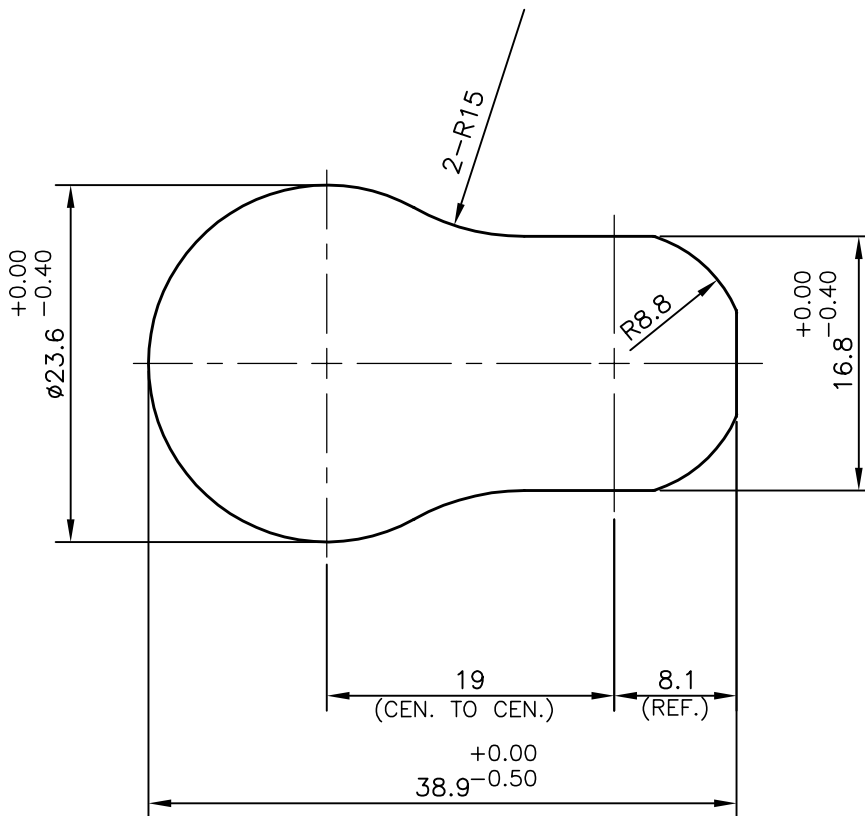
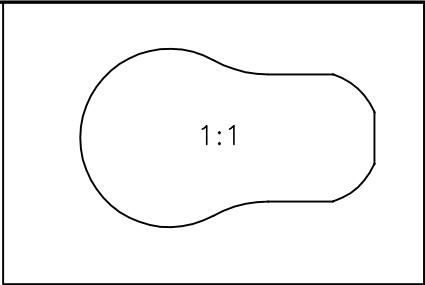

**JINDAL ALUMINIUM LTD.**  
BANGALORE-560073 (INDIA)

	NAME	DATE
DRAWN	J.P.KAUSHIK	07-03-2013
CHECKED		
APPROVED	S.S.GARG	21-03-2013

1. ALL DIMENSIONS ARE IN mm.
2. ROUND OFF ALL SHARP CORNERS WITH 0.40 mm.
3. TOLERANCES WILL BE AS PER,BS:EN-755-9 UNLESS OTHERWISE SPECIFIED

SCALE	2:1
AREA mm <sup>2</sup>	697.473
PERIMETER mm.	103.605
WEIGHT kg/m	1.883

PARTY'S NAME: WONJIN AUTOPARTS INDIA PVT. LTD.  
MARAMALAI NAGAR

DRAWING No.	SECTION No.
P-12194-1	-
S3705	S3705
28083	28083

PARTY'S DRAWING No.: SJ 01089

ALLOY & TEMPER: 6061 O

DESCRIPTION: FORGING J/F-EXTRUSION