

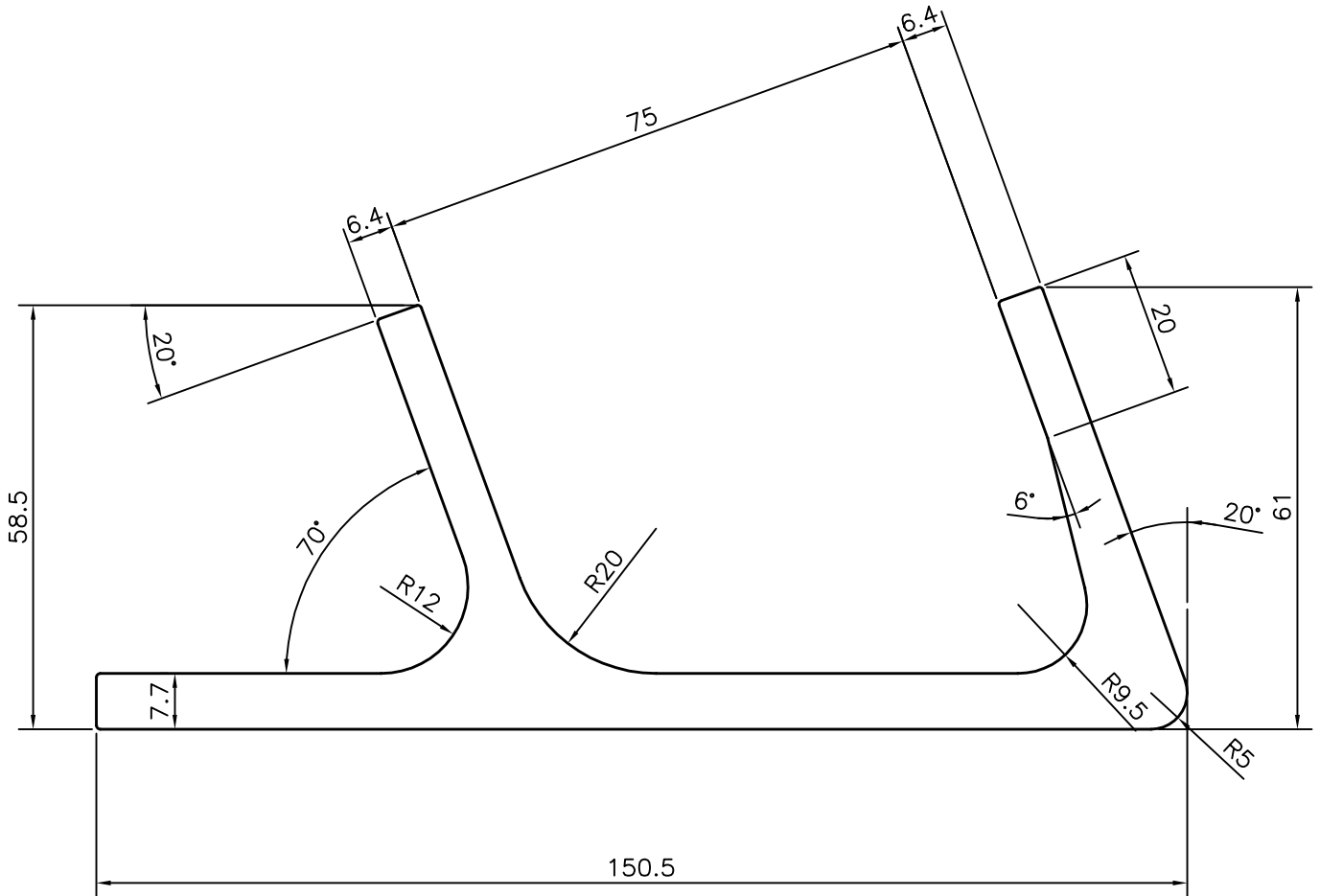

P-11416-2

S3182

28086

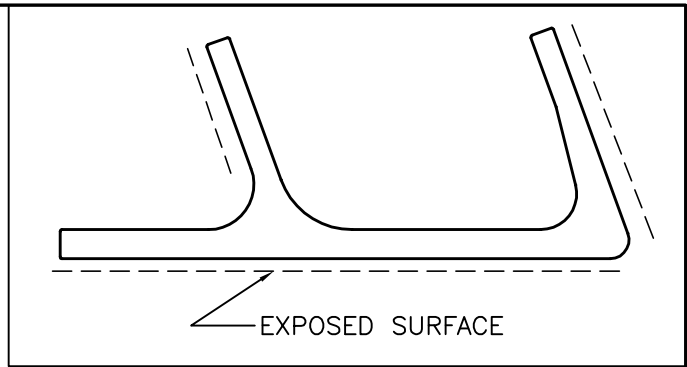

- 1. BEND & TWIST = 1.7mm/M
- 2. ANGULARITY = ±1°
- 3. FLATNESS = 1.0mm (ON WIDTH)

 SYMBOL OF QUALITY AN ISO 9001 COMPANY	JINDAL ALUMINIUM LTD. BANGALORE-560073 (INDIA)	NAME		DATE
		DRAWN	J.P.KAUSHIK	23-01-2012
1. ALL DIMENSIONS ARE IN mm. 2. ROUND OFF ALL SHARP CORNERS WITH 0.50 mm. 3. TOLERANCES WILL BE AS PER IS:3965-1981 UNLESS OTHERWISE SPECIFIED		CHECKED		
		APPROVED		B.NATARAJ
PARTY'S NAME ORANGE SORTING MACHINES (INDIA) PVT. LTD., COIMBATORE		SCALE		1:1
		AREA mm ²		2045.423
PARTY'S DRAWING No. MECDEVG00108		PERIMETER mm.		502.418
		WEIGHT kg/m		5.523
ALLOY & TEMPER 63400 WP		DRAWING No.		P-11416-2
		SECTION No.		-
DESCRIPTION MISC. SECTION (VIBRATOR PROFILE)		S3182		S3182
		28086		28086