

P-11530-1

S3212

28090

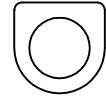

SCALE :- 1:1

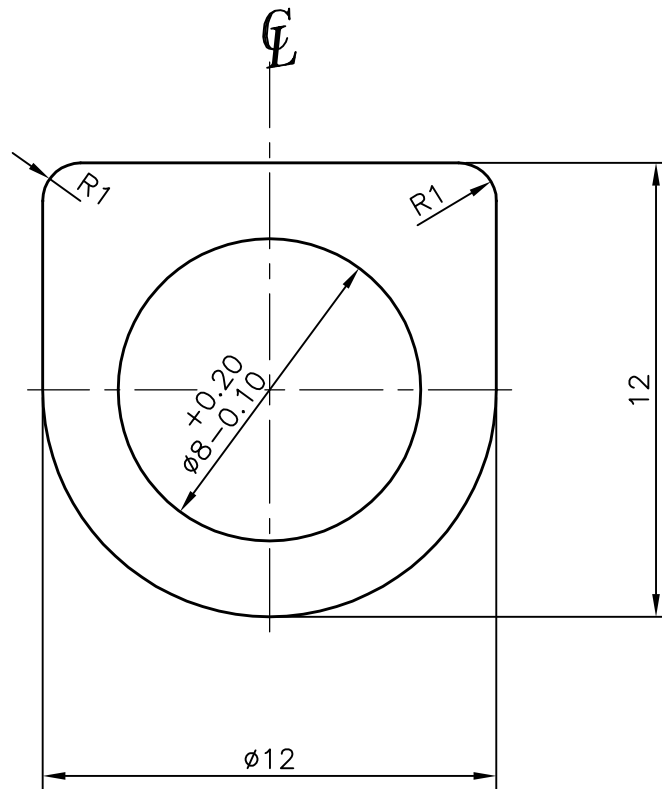

SYMBOL OF QUALITY
AN ISO 9001 COMPANY

JINDAL ALUMINIUM LTD.
BANGALORE-560073 (INDIA)

	NAME	DATE
DRAWN	PARVESH	17-02-2012
CHECKED		
APPROVED	S.S.GARG	09-03-2012

1. ALL DIMENSIONS ARE IN mm.
2. ROUND OFF ALL SHARP CORNERS WITH 0.40 mm.
3. TOLERANCES WILL BE AS PER, IS:6477-1983 UNLESS OTHERWISE SPECIFIED

SCALE	5:1
AREA mm ²	77.854
PERIMETER mm.	41.991
WEIGHT kg/m	0.21

PARTY'S NAME	WONJIN AUTOPARTS INDIA PVT. LTD. MARAMALAI NAGAR	DRAWING No.	P-11530-1	SECTION No.	-
PARTY'S DRAWING No.	AS PER DRAWING	S3212	S3212		
ALLOY & TEMPER	6061 T6	28090	28090		
DESCRIPTION	PA & HA CONNECTOR PROFILE				