

P-11575-1

S3234

28093

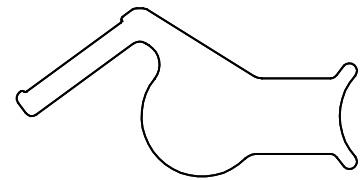

SCALE :- 1:1

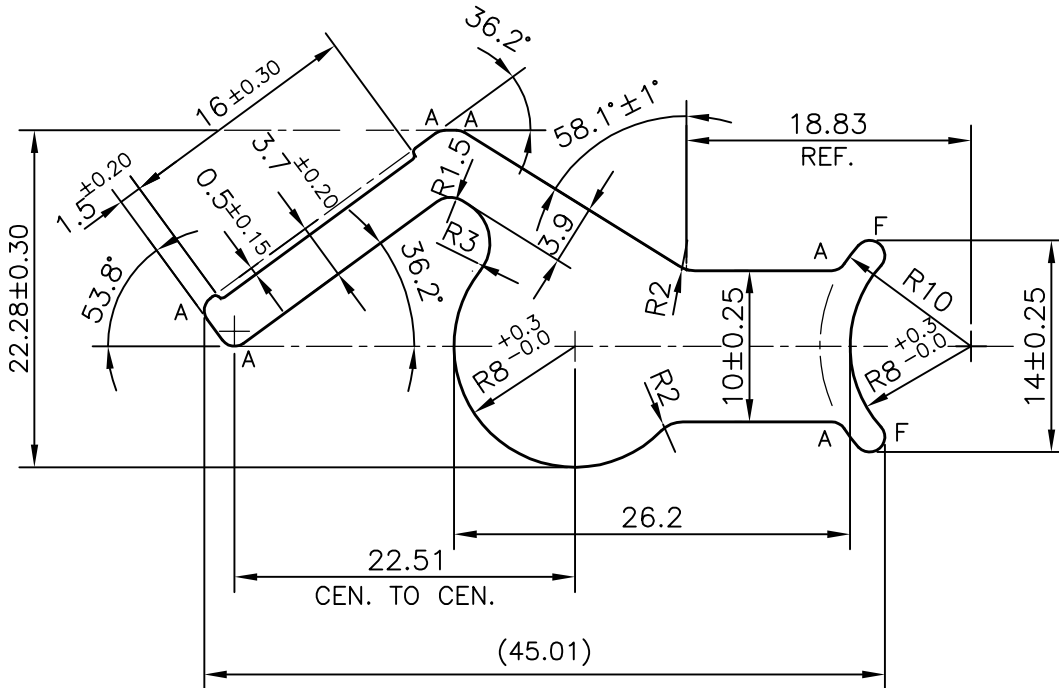

A = RADIUS 1 mm. (6 PLACES)

F = FULL RADIUS (2 PLACES)

ROUND OFF ALL SHARP CORNERS WITH 0.30 mm.



SYMBOL OF QUALITY
AN ISO 9001 COMPANY

JINDAL ALUMINIUM LTD.
BANGALORE-560073 (INDIA)

	NAME	DATE
DRAWN	J.P.KAUSHIK	22-03-2012
CHECKED		
APPROVED	S.S.GARG	28-03-2012

1. ALL DIMENSIONS ARE IN mm.
2. ROUND OFF ALL SHARP CORNERS WITH 0.30 mm.
3. TOLERANCES WILL BE AS PER BS:EN-755-9, UNLESS OTHERWISE SPECIFIED

SCALE	2:1
AREA mm ²	424.707
PERIMETER mm.	134.53
WEIGHT kg/m	1.147

PARTY'S NAME	PRECISION COMPONENTS INDIA, MOHALI	DRAWING No.	SECTION No.
PARTY'S DRAWING No.	PCI-689	P-11575-1	-
ALLOY & TEMPER	6063 T6	S3234	S3234
		28093	28093
DESCRIPTION	MISC. SECTION		