

P-13077

S3895

28103

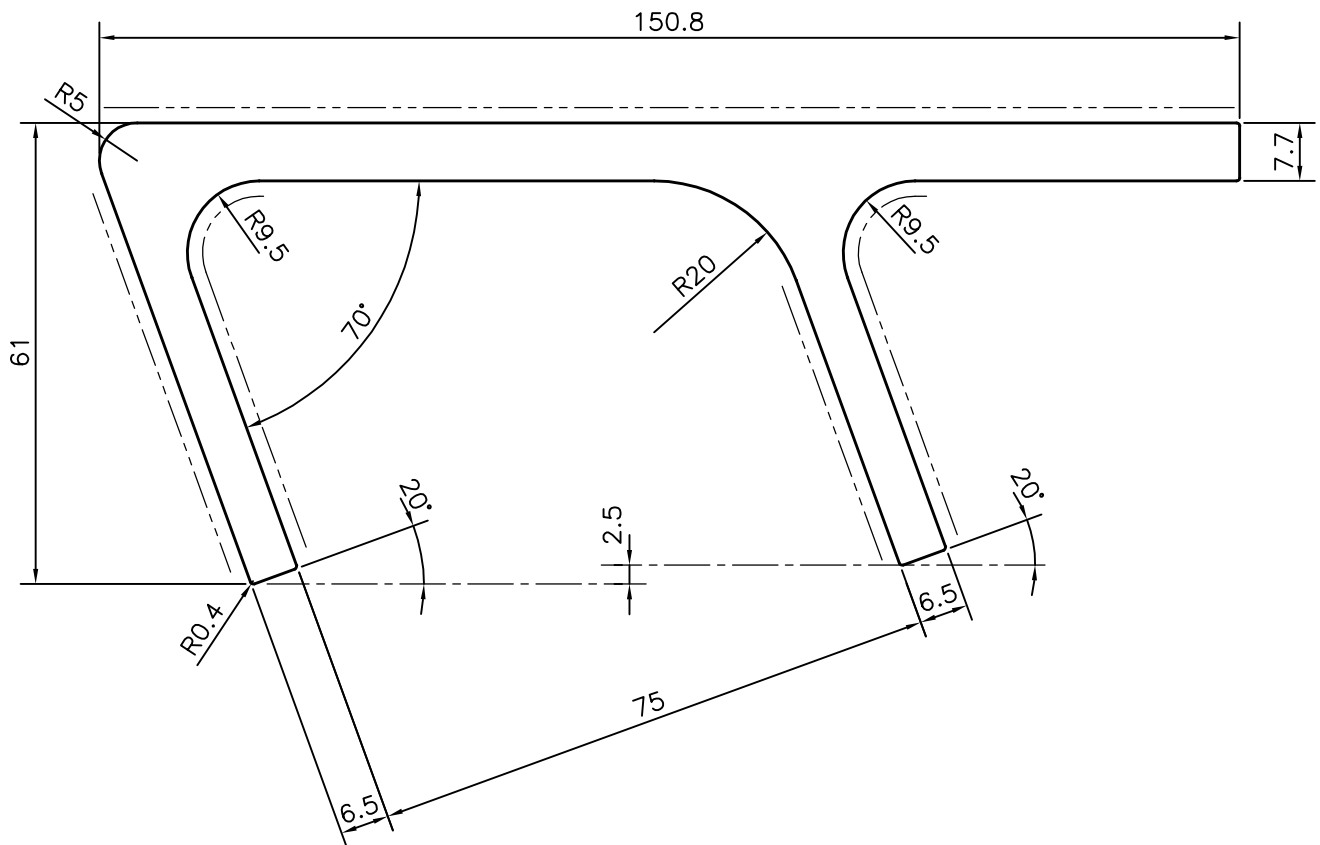

----- EXPOSED SURFACE

TOLERANCES ON OVERALL WIDTHS & WIDTHS ACROSS FLATS OF BARS, & REGULAR SECTIONS

UPTO 6.40mm - ±0.20	UPTO 32.0mm - ±0.38	UPTO 120.0mm - ±0.85	1. STRAIGHTNESS=1.7mm/M 2. TWIST=1.7mm/M 3. ANGULARITY= ±2° 4. FLATNESS =0.007xWIDTH
UPTO 10.0mm - ±0.23	UPTO 50.0mm - ±0.46	UPTO 160.0mm - ±1.02	
UPTO 12.0mm - ±0.25	UPTO 60.0mm - ±0.53	UPTO 200.0mm - ±1.14	
UPTO 16.0mm - ±0.28	UPTO 80.0mm - ±0.69	UPTO 250.0mm - ±1.40	
UPTO 25.0mm - ±0.30	UPTO 100.0mm - ±0.75	UPTO 300.0mm - ±1.65	



SYMBOL OF QUALITY
AN ISO 9001 COMPANY

JINDAL ALUMINIUM LTD.
BANGALORE-560073 (INDIA)

	NAME	DATE
DRAWN	PARVESH	07-10-2013
CHECKED		
APPROVED	S.S.GARG	16-10-2013

1. ALL DIMENSIONS ARE IN mm.
2. ROUND OFF ALL SHARP CORNERS WITH 0.40 mm.
3. TOLERANCES WILL BE AS PER IS:3965-1981, UNLESS OTHERWISE SPECIFIED

SCALE	1:1
AREA mm ²	1981.45
PERIMETER mm.	508.37
WEIGHT kg/m	5.350

PARTY'S NAME	ORANGE SORTING MACHINES (I) PVT. LTD., COIMBATORE	DRAWING No.	P-13077	SECTION No.	-
PARTY'S DRAWING No.	AS PER DRAWING		S3895		S3895
ALLOY & TEMPER	63400 WP		28103		28103
DESCRIPTION	INDUSTRIAL SECTION-VIBRATOR PROFILE (PLUNGER V1)				