

P-11655-1

X1594

28114

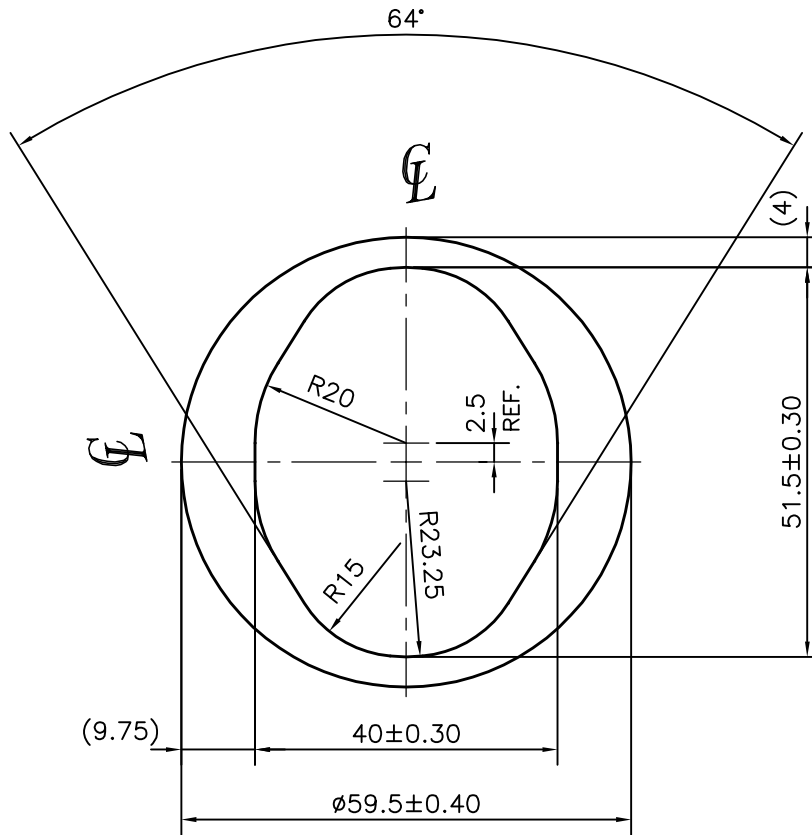

SYMBOL OF QUALITY
AN ISO 9001 COMPANY

JINDAL ALUMINIUM LTD.
BANGALORE-560073 (INDIA)

	NAME	DATE
DRAWN	PARVESH	12-05-2012
CHECKED		
APPROVED	J.N.RAI	18-05-2012
SCALE		1:1
AREA mm ²		1160.379
PERIMETER mm.		186.925
WEIGHT kg/m		3.133
DRAWING No.	SECTION No.	
P-11655-1	-	
X1594	X1594	
28114	28114	

1. ALL DIMENSIONS ARE IN mm.
2. ROUND OFF ALL SHARP CORNERS WITH 0.40 mm.
3. TOLERANCES WILL BE AS PER IS:6477-1983, UNLESS OTHERWISE SPECIFIED

PARTY'S NAME	JARAA CNC PRODUCTS, HOSUR
PARTY'S DRAWING No.	1A1583-15 & AS PER REQUIREMENT
ALLOY & TEMPER	6061 T6
DESCRIPTION	MISC. TUBE