

P-11566-2

S3264

28116

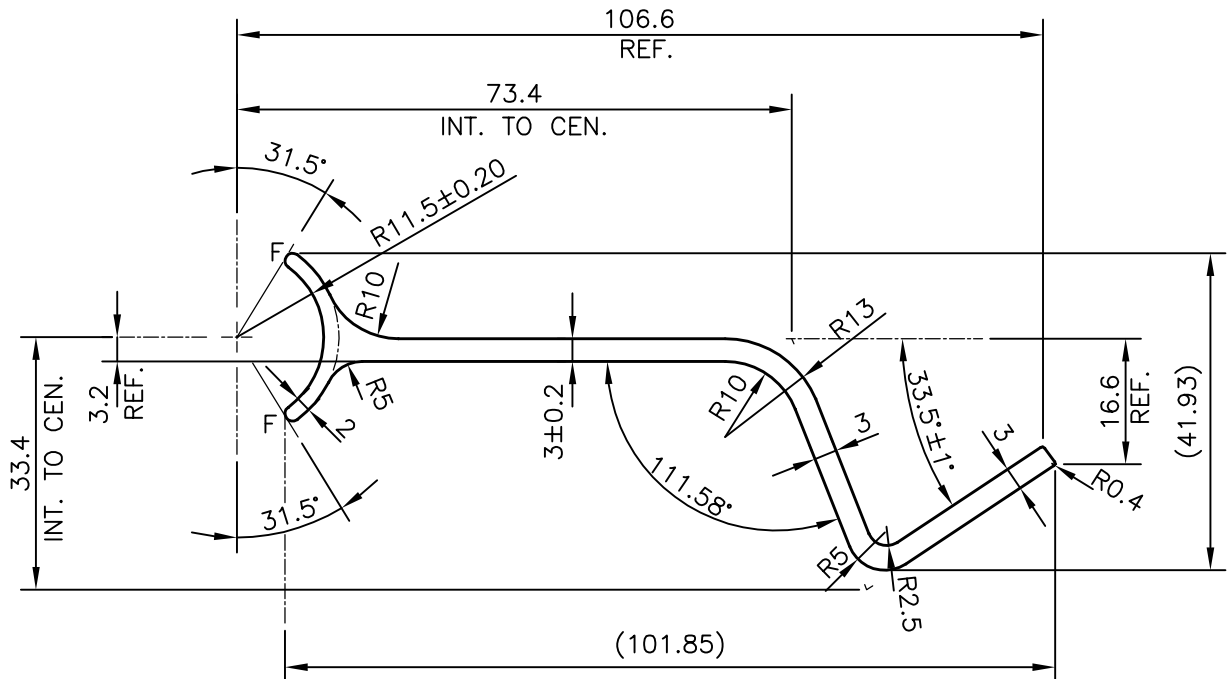

F = FULL RADIUS (2 PLACES)



SYMBOL OF QUALITY  
AN ISO 9001 COMPANY

**JINDAL ALUMINIUM LTD.**  
BANGALORE-560073 (INDIA)

	NAME	DATE
DRAWN	PARVESH	23-02-2012
CHECKED		
APPROVED	S.S.CARG	09-05-2012

1. ALL DIMENSIONS ARE IN mm.
2. ROUND OFF ALL SHARP CORNERS WITH 0.40 mm.
3. TOLERANCES WILL BE AS PER IS:3965-1981, UNLESS OTHERWISE SPECIFIED

SCALE	1:1
AREA mm <sup>2</sup>	406.401
PERIMETER mm.	278.393
WEIGHT kg/m	1.097

PARTY'S NAME	WONJIN AUTOPARTS INDIA PVT. LTD. MARAMALAI NAGAR	DRAWING No.	P-11566-2	SECTION No.	-
PARTY'S DRAWING No.	VP7NIH-19D720-AB		S3264		S3264
ALLOY & TEMPER	6005 T5		28116		28116
DESCRIPTION	BRKT (B) MOUNTING COND				