

P-11841-1

S3361

28123

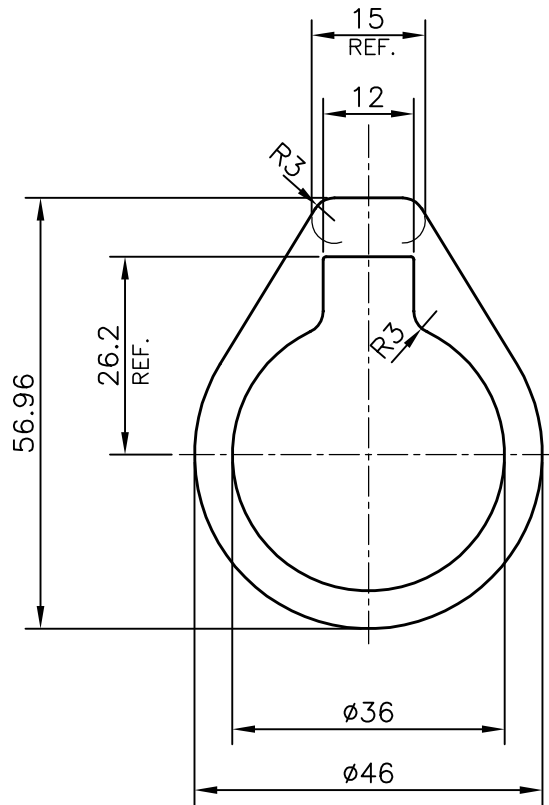

SYMBOL OF QUALITY  
AN ISO 9001 COMPANY

**JINDAL ALUMINIUM LTD.**  
BANGALORE-560073 (INDIA)

	NAME	DATE
DRAWN	PARVESH	21-06-2012
CHECKED		
APPROVED	S.S.GARG	27-06-2012
SCALE		1:1
AREA mm <sup>2</sup>		800.87
PERIMETER mm.		160.766
WEIGHT kg/m		2.162
DRAWING No.	SECTION No.	
P-11841-1	-	
S3361	S3361	
28123	28123	

1. ALL DIMENSIONS ARE IN mm.
2. ROUND OFF ALL SHARP CORNERS WITH 0.40 mm.
3. TOLERANCES WILL BE AS PER IS:6477-1983, UNLESS OTHERWISE SPECIFIED

PARTY'S NAME	WENTEX INDIA PVT. LTD., MANESAR
PARTY'S DRAWING No.	REDUCERS STAGE 3
ALLOY & TEMPER	6063 T6
DESCRIPTION	MISC. SECTION