

P-12846-1

S3806

28124

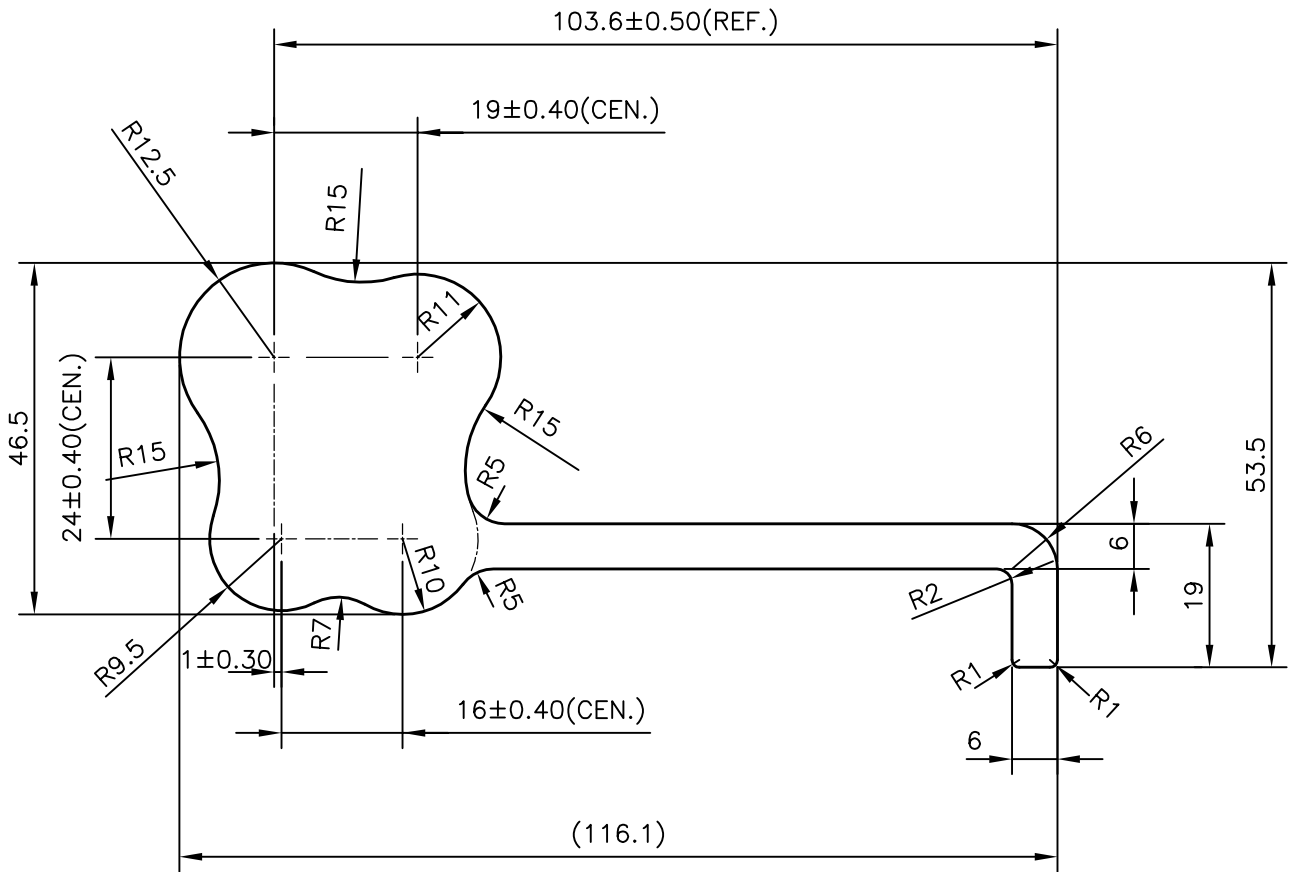

TOLERANCE CHART CD = CIRCUMSCRIBING CIRCLE

	CD≤100	100<CD≤200	200<CD<300	300<CD<500
UPTO 10mm - ±0.25	±0.30	±0.35	±0.40	
10.0 -25.0 - ±0.30	±0.40	±0.50	±0.60	
25.0 -50.0 - ±0.50	±0.60	±0.80	±0.90	
50.0 -100.0 - ±0.70	±0.90	±1.10	±1.30	
100 - 150 - -	±1.10	±1.30	±1.50	
150 - 200 - -	±1.3	±1.50	±1.80	
200 - 300 - -	-	±1.70	±2.10	
300 - 450 - -	-	-	±2.80	

 SYMBOL OF QUALITY AN ISO 9001 COMPANY	JINDAL ALUMINIUM LTD. BANGALORE-560073 (INDIA)	NAME	DATE	
		DRAWN	J.P.KAUSHIK	06-07-2013
		CHECKED		
		APPROVED	S.S.GARG	
			20-07-2013	
1. ALL DIMENSIONS ARE IN mm. 2. ROUND OFF ALL SHARP CORNERS WITH 0.40 mm. 3. TOLERANCES WILL BE AS PER BS:EN-755-9 UNLESS OTHERWISE SPECIFIED		SCALE	1:1	
		AREA mm ²	2116.773	
		PERIMETER mm.	328.41	
PARTY'S NAME		WONJIN AUTOPARTS INDIA PVT. LTD., MARAMALAI NAGAR	WEIGHT kg/m	5.715
				DRAWING No.
PARTY'S DRAWING No.		F742QQDAB01 000	P-12846-1	-
ALLOY & TEMPER		6005 T5	S3806	S3806
			28124	28124
DESCRIPTION		CONDENSER JOINT FLANGE SECTION		