

P-11803-2

S3424

28126

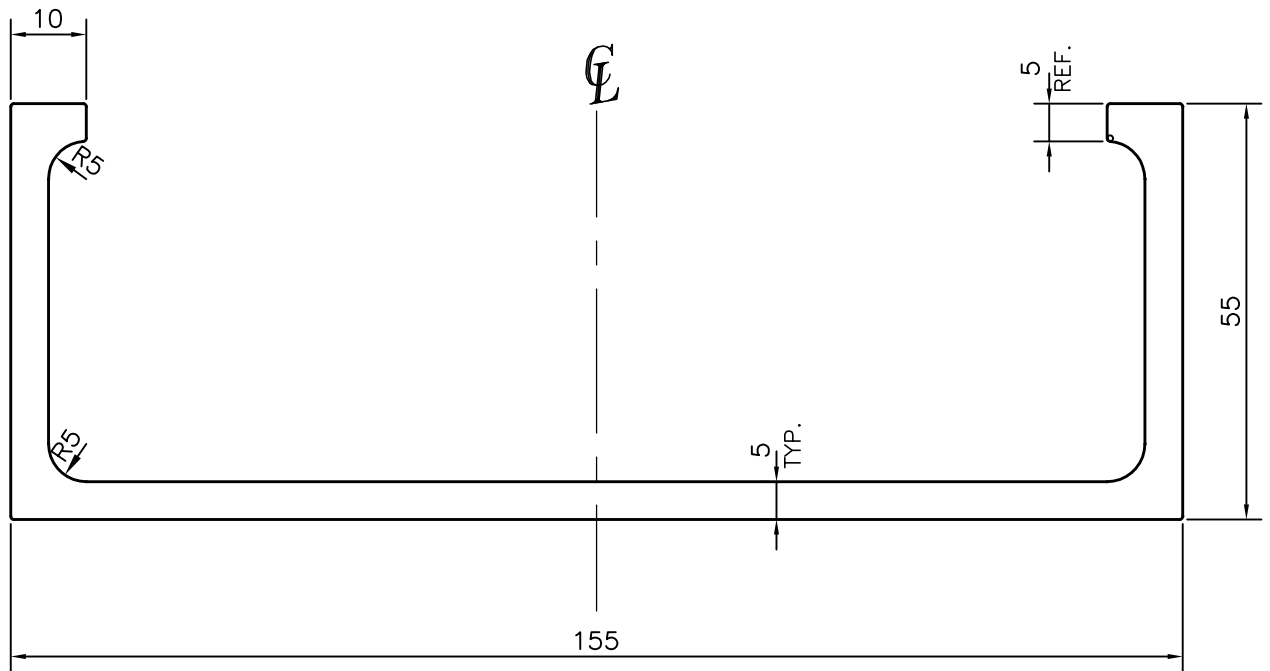

1. STRAIGHTNESS=0.75mm/M
2. TWIST=0.75mm/M
3. ANGULARITY= $\pm 1.5^\circ$



SYMBOL OF QUALITY
AN ISO 9001 COMPANY

JINDAL ALUMINIUM LTD.
BANGALORE-560073 (INDIA)

	NAME	DATE
DRAWN	PARVESH	26-07-2012
CHECKED		
APPROVED	S.S.GARG	04-08-2012
SCALE		1:1
AREA mm ²		1346.045
PERIMETER mm.		530.071
WEIGHT kg/m		3.634
DRAWING No.	SECTION No.	
P-11803-2	-	
S3424	S3424	
28126	28126	

1. ALL DIMENSIONS ARE IN mm.
2. ROUND OFF ALL SHARP CORNERS WITH 0.40 mm.
3. TOLERANCES WILL BE AS PER IS:3965-1981, UNLESS OTHERWISE SPECIFIED

PARTY'S NAME	JASH ENGINEERING LTD.,INDORE
PARTY'S DRAWING No.	JE/SG/GEN/1318
ALLOY & TEMPER	6061 T6
DESCRIPTION	WATER CONTROL EQUIPMENT