

P-11802-2

S3423

28127

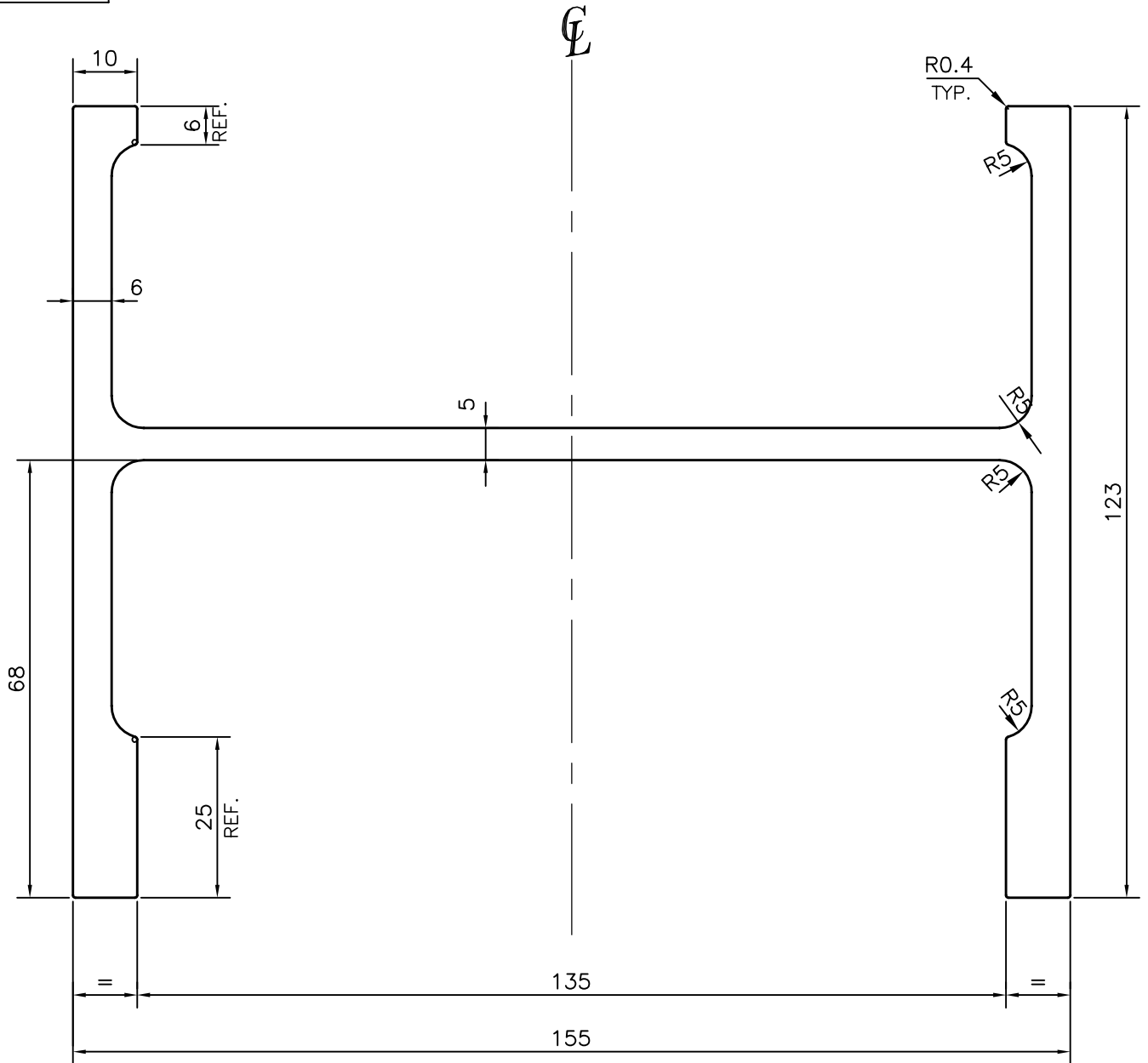

1. STRAIGHTNESS=0.75mm/M
2. TWIST=0.75mm/M
3. ANGULARITY= ±1.5°



SYMBOL OF QUALITY
AN ISO 9001 COMPANY

JINDAL ALUMINIUM LTD.
BANGALORE-560073 (INDIA)

	NAME	DATE
DRAWN	PARVESH	26-07-2012
CHECKED		
APPROVED	S.S.GARG	04-08-2012
SCALE		1:1
AREA mm ²		2478.481
PERIMETER mm.		805.446
WEIGHT kg/m		6.692
DRAWING No.	SECTION No.	
P-11802-2	-	
S3423	S3423	
28127	28127	

1. ALL DIMENSIONS ARE IN mm.
2. ROUND OFF ALL SHARP CORNERS WITH 0.40 mm.
3. TOLERANCES WILL BE AS PER IS:3965-1981, UNLESS OTHERWISE SPECIFIED

PARTY'S NAME	JASH ENGINEERING LTD.,INDORE
PARTY'S DRAWING No.	JE/SG/GEN/1317
ALLOY & TEMPER	6061 T6
DESCRIPTION	WATER CONTROL EQUIPMENT