

P-12403-1

S3617

28133

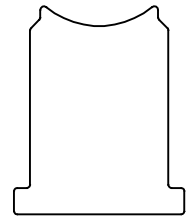

SCALE 1:1

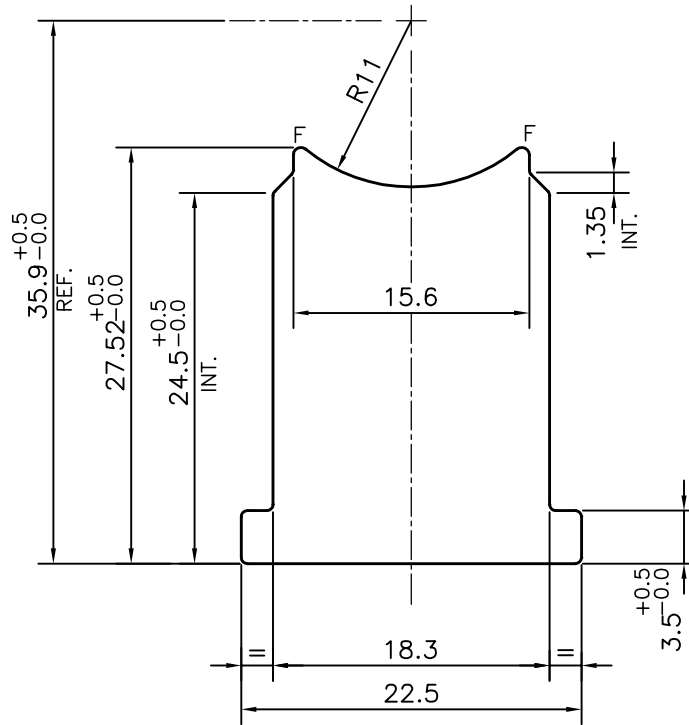

F = FULL RADIUS (2 PLACES)



SYMBOL OF QUALITY  
AN ISO 9001 COMPANY

**JINDAL ALUMINIUM LTD.**  
BANGALORE-560073 (INDIA)

	NAME	DATE
DRAWN	PARVESH	08-01-2013
CHECKED		
APPROVED	S.S.GARG	25-01-2013
SCALE		2:1
AREA mm <sup>2</sup>		486.251
PERIMETER mm.		98.157
WEIGHT kg/m		1.313
DRAWING No.		SECTION No.
P-12403-1		-
S3617		S3617
28133		28133

1. ALL DIMENSIONS ARE IN mm.
2. ROUND OFF ALL SHARP CORNERS WITH 0.40 mm.
3. TOLERANCES WILL BE AS PER IS:3965-1981, UNLESS OTHERWISE SPECIFIED

PARTY'S NAME	PYN PRECISION COMPONENTS, FARIDABAD
PARTY'S DRAWING No.	924X44LA1A-00
ALLOY & TEMPER	DA3103BD' -'O'
DESCRIPTION	CONN O-RING,IN