

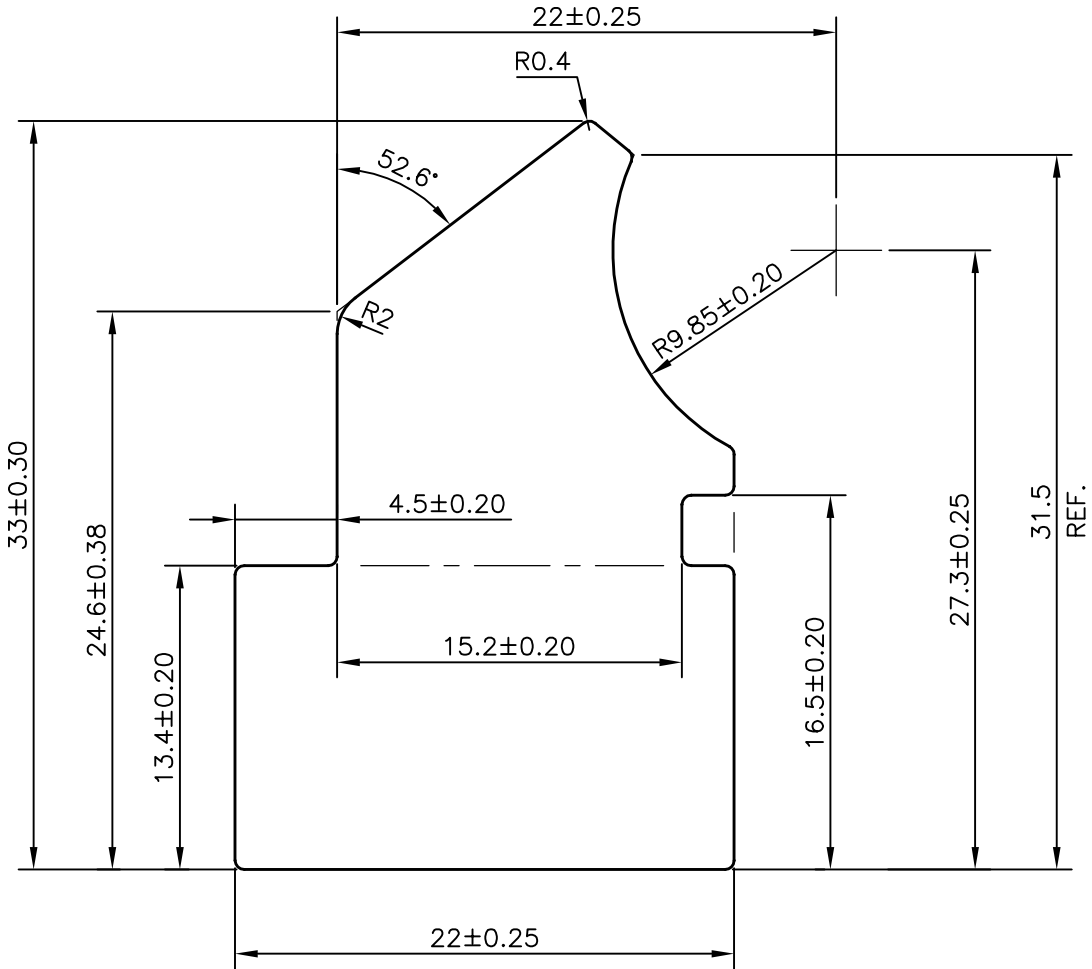

P-12051
S3487
28139

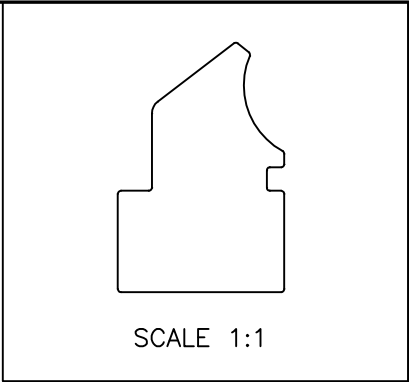

 SYMBOL OF QUALITY AN ISO 9001 COMPANY	JINDAL ALUMINIUM LTD. BANGALORE-560073 (INDIA)		NAME	DATE
		DRAWN	RAGHAVENDRA	21-09-2012
		CHECKED		
		APPROVED	S.S.GARG	01-10-2012
1. ALL DIMENSIONS ARE IN mm. 2. ROUND OFF ALL SHARP CORNERS WITH 0.40 mm. 3. TOLERANCES WILL BE AS PER BS:EN-12020-2 UNLESS OTHERWISE SPECIFIED		SCALE		3:1
		AREA mm ²		521.651
		PERIMETER mm.		104.173
		WEIGHT kg/m		1.408
PARTY'S NAME	GLOBAL AUTOTECH LTD., NOIDA	DRAWING No.	SECTION No.	
PARTY'S DRAWING No.	TC-EX-193-00	P-12051	-	
ALLOY & TEMPER	DA3103BD "O"	S3487	S3487	
		28139	28139	
DESCRIPTION/END USE	TUBE CONNECTOR SECTION			