

P-10932-1

S3071

28142

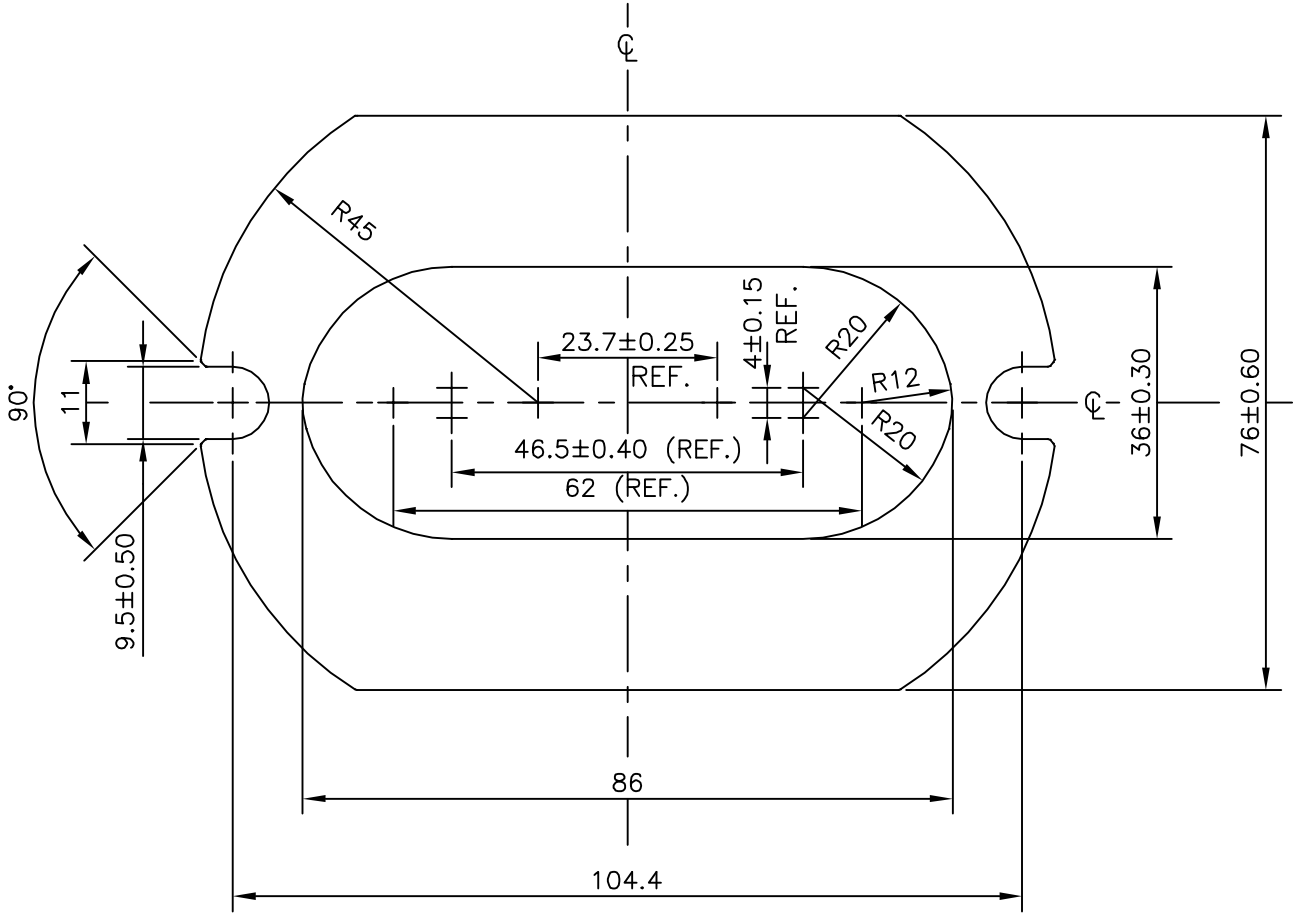

SYMBOL OF QUALITY
AN ISO 9001 COMPANY

JINDAL ALUMINIUM LTD.
BANGALORE-560073 (INDIA)

	NAME	DATE
DRAWN	J.P.KAUSHIK	23-07-2011
CHECKED		
APPROVED	S.S.GARG	25-10-2011
SCALE		1:1
AREA mm ²		4776.216
PERIMETER mm.		350.89
WEIGHT kg/m		12.896
DRAWING No.	SECTION No.	
P-10932-1	-	
S3071	S3071	
28142	28142	

1. ALL DIMENSIONS ARE IN mm.
2. ROUND OFF ALL SHARP CORNERS WITH 0.40 mm.
3. TOLERANCES WILL BE AS PER BS:EN-12020-2 UNLESS OTHERWISE SPECIFIED

PARTY'S NAME	DEPARTMENT OF ATOMIC ENERGY, INDORE
PARTY'S DRAWING No.	CAT/EAP/62600/314/DD REV.No 2A
ALLOY & TEMPER	6063 T6
DESCRIPTION	INDUS-2-STRAIGHT CHAMBER