

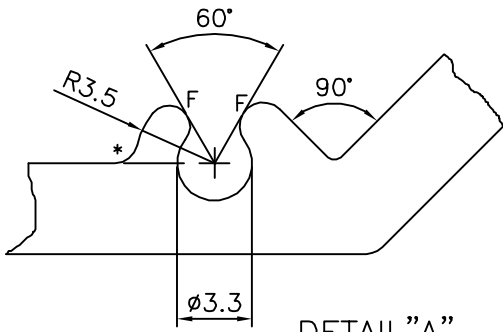

P-12111
S3495
28144

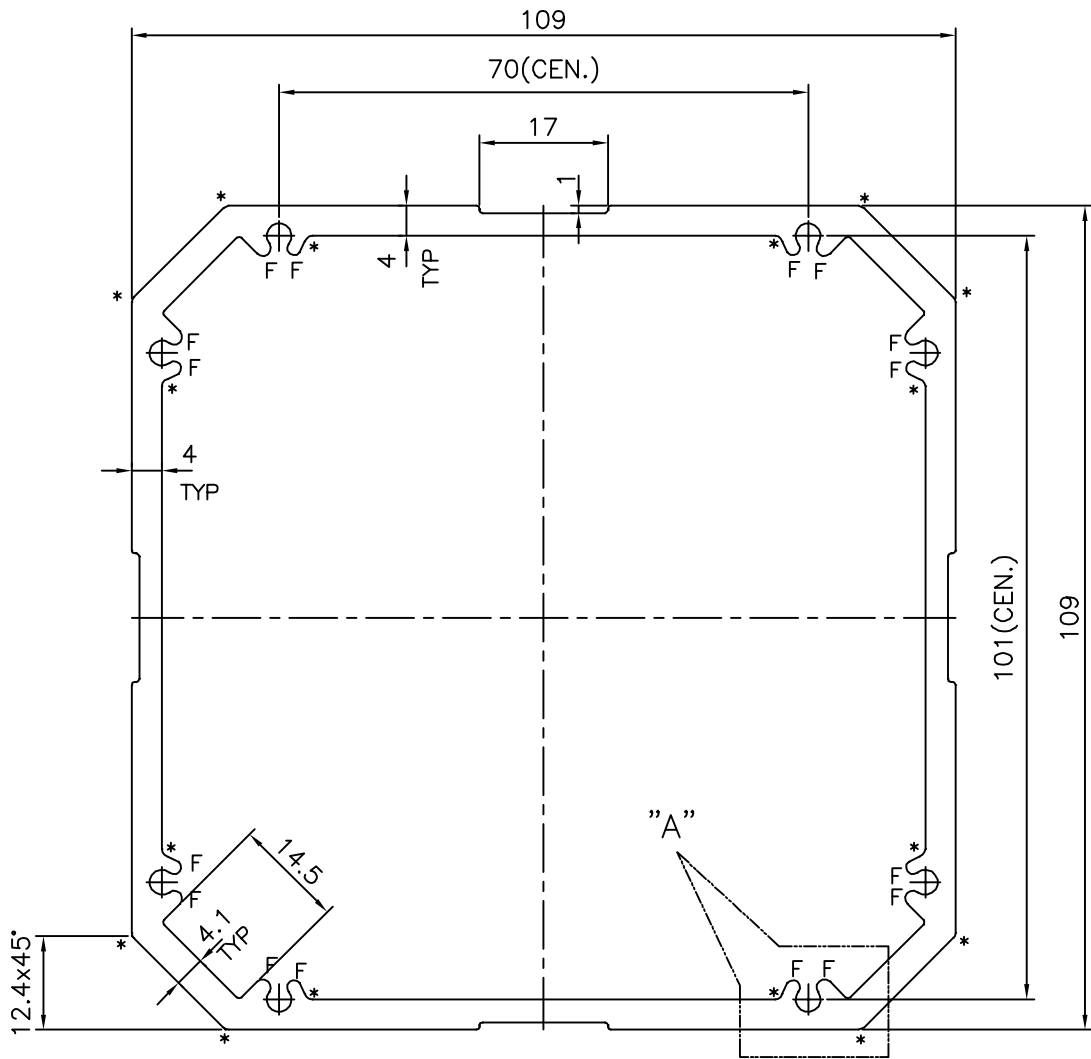

DETAIL "A"
SCALE 3:1

* = 1.0 RADIUS (16 PLACES)
F = FULL RADIUS (16 PLACES)

 SYMBOL OF QUALITY AN ISO 9001 COMPANY	JINDAL ALUMINIUM LTD. BANGALORE-560073 (INDIA)	DRAWN	NAME	DATE
		CHECKED	J.P.KAUSHIK	04-10-2012
1. ALL DIMENSIONS ARE IN mm. 2. ROUND OFF ALL SHARP CORNERS WITH 0.40 mm. 3. TOLERANCES WILL BE AS PER, IS:6477-1983 UNLESS OTHERWISE SPECIFIED		APPROVED	S.S.GARG	08-10-2012
		SCALE		1:1
PARTY'S NAME APPASAMY ASSOCIATES, CHENNAI		AREA mm ²		1570.339
		PERIMETER mm.		411.854
PARTY'S DRAWING No. 41-10050-00		WEIGHT kg/m		4.240
		DRAWING No.	SECTION No.	
ALLOY & TEMPER HE9 WP		P-12111	-	
		S3495	S3495	
DESCRIPTION MISC. SECTION (INNRE COLUMN)(INSTRUMENT STAND)		28144	28144	