

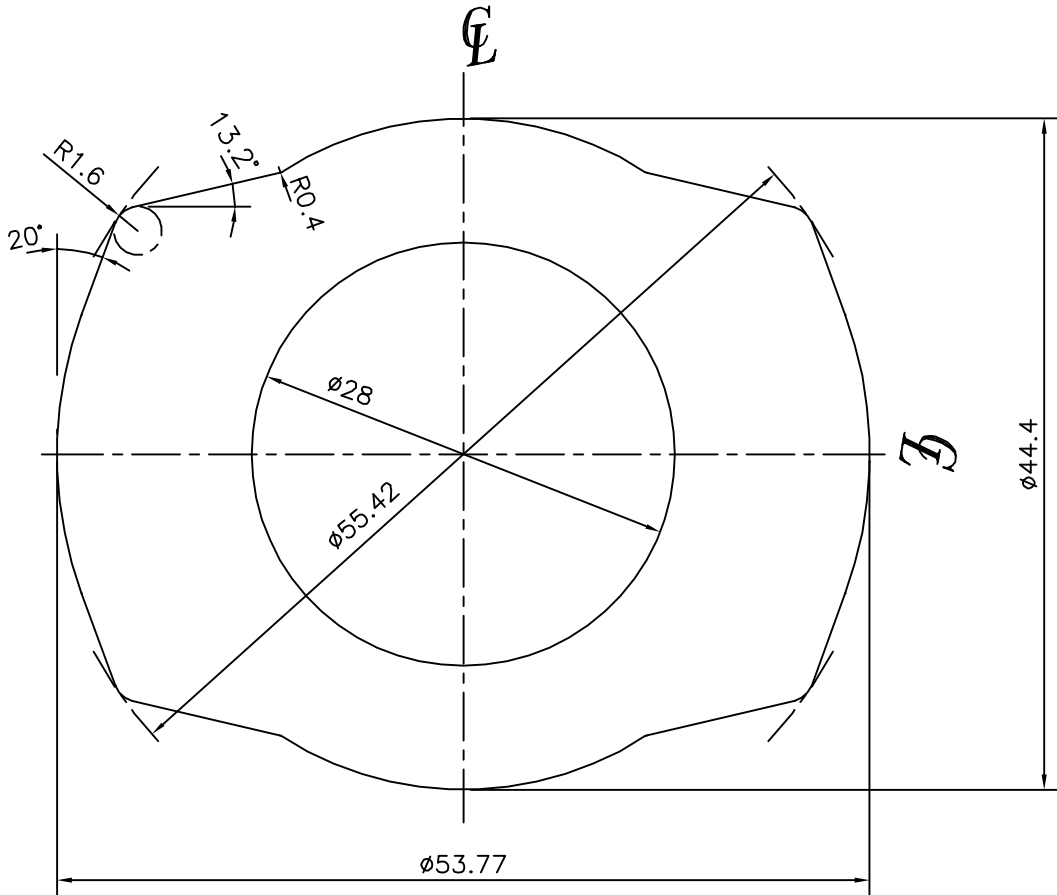

P-12190
S3549
28147

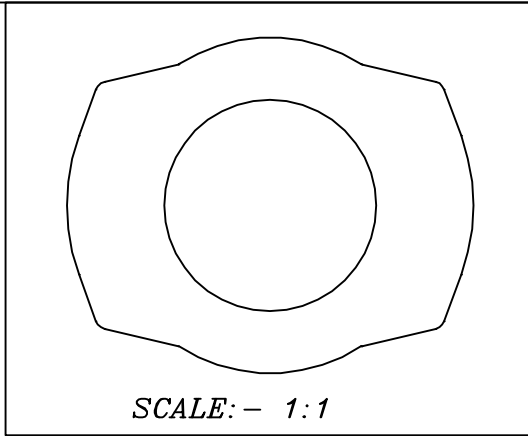

1. STRAIGHTNESS=1.5mm/M
2. TWIST=1.5mm/M
3. OVALITY=±0.50mm

 SYMBOL OF QUALITY AN ISO 9001 COMPANY	<b>JINDAL ALUMINIUM LTD.</b> BANGALORE-560073 (INDIA)	NAME		DATE	
		DRAWN	PARVESH	31-10-2012	
1. ALL DIMENSIONS ARE IN mm. 2. ROUND OFF ALL SHARP CORNERS WITH 0.40 mm. 3. TOLERANCES WILL BE AS PER IS:6477-1983 , UNLESS OTHERWISE SPECIFIED		CHECKED			
		APPROVED	S.S.GARG	08-11-2012	
PARTY'S NAME		TITAN INDUSTRIES LTD., HOSUR		SCALE	2:1
		PARTY'S DRAWING No. TS-25-112		AREA mm <sup>2</sup>	1309.703
ALLOY & TEMPER		6063 T6		PERIMETER mm.	161.353
		DESCRIPTION		WATCH CASE	WEIGHT kg/m
				DRAWING No.	SECTION No.
				P-12190	-
				S3549	S3549
				28147	28147