

P-12291
X1643
28149

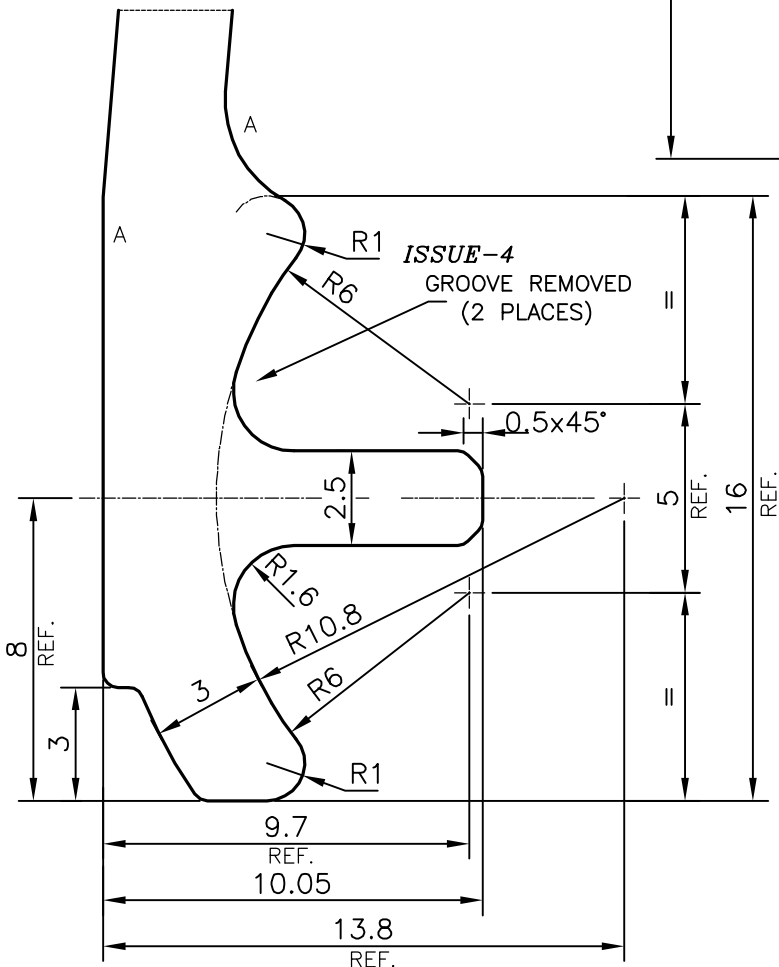
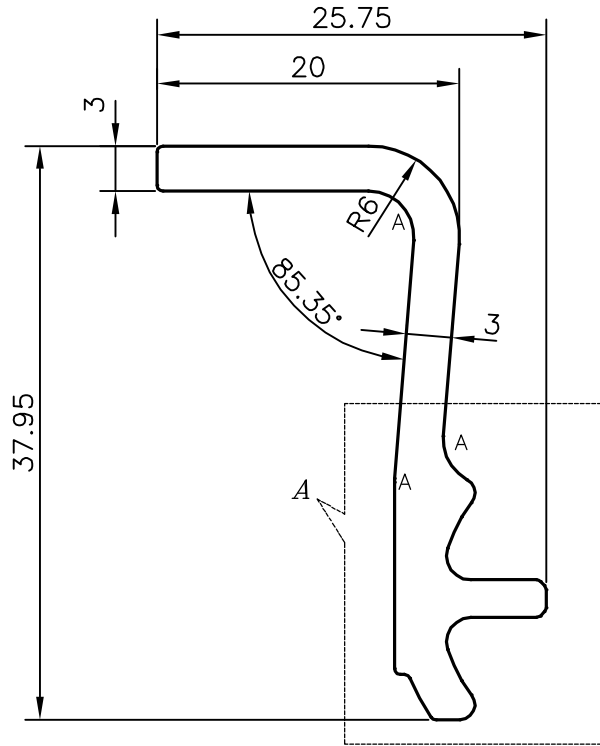

DETAIL OF "A"  
SCALE 5:1

ISSUE-4  
WEIGHT ALSO CHANGED  
FROM 0.511 TO 0.514 kg/m.

A = RADIUS 3 mm. (3 PLACES)

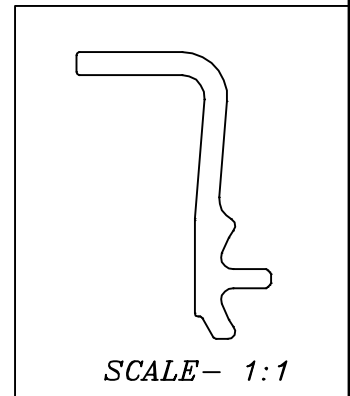

 SYMBOL OF QUALITY AN ISO 9001 COMPANY	<b>JINDAL ALUMINIUM LTD.</b> BANGALORE-560073 (INDIA)	NAME	DATE
		DRAWN	PARVESH 31-08-2015
		CHECKED	
		APPROVED	S.S.GARG 19-09-2015
		SCALE	2:1
		AREA mm <sup>2</sup>	190.21
		PERIMETER mm.	125.115
		WEIGHT kg/m	0.514
PARTY'S NAME	YOONWOO AUTOMOTIVE INDIA PVT. LTD., PUNE	DRAWING No.	SECTION No.
PARTY'S DRAWING No.	AS PER AUTOCAD DRAWING	P-12291	-
ALLOY & TEMPER	6005 T5	X1643	X1643 (ISSUE-3)
DESCRIPTION	BRACKET LH BOTTOM	28149	28149 (ISSUE-4)