

P-12307-2

S3584

28150

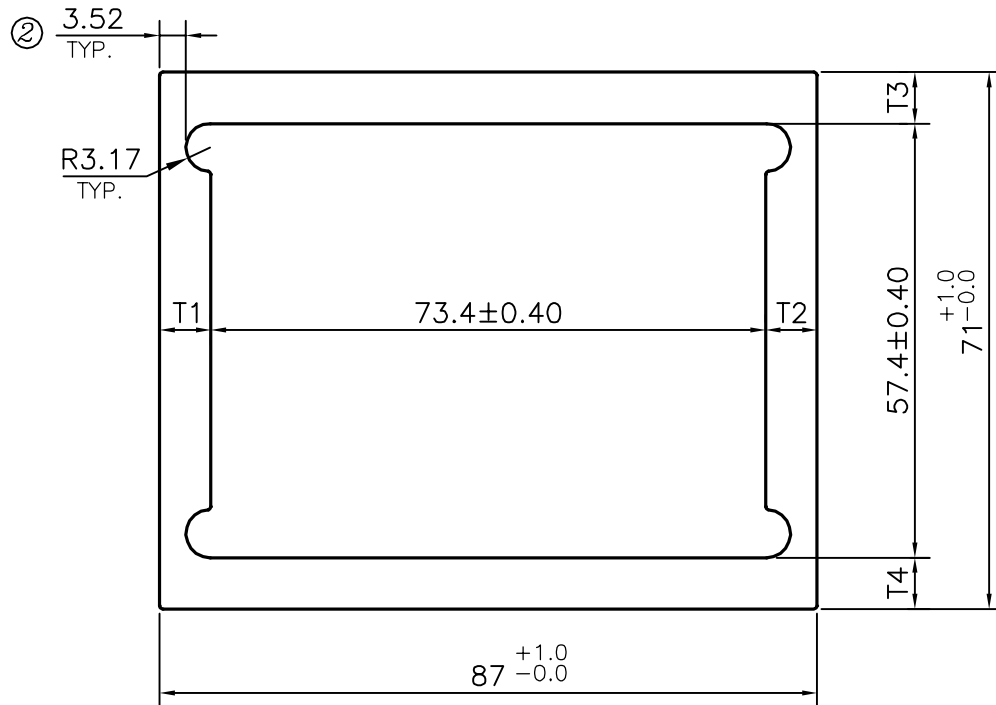

➔ **OPPOSITE WALL THICKNESS MAXIMUM 0.3 mm.**
VARIATION PERMISSIBLE.
 eg. - $T1 - T2 = 0.3 \text{ mm. (MAXIMUM)}$

ISSUE (2) :-

DIMENSION CHANGED FROM 3.17 TO 3.52 mm.

WEIGHT ALSO CHANGED FROM 5.100 kg/m TO 5.124 kg/m.

 SYMBOL OF QUALITY AN ISO 9001 COMPANY	JINDAL ALUMINIUM LTD. BANGALORE-560073 (INDIA)		NAME	DATE
		DRAWN	PARVESH	06-07-2013
		CHECKED		
		APPROVED	S.S.GARG	08-07-2013
1. ALL DIMENSIONS ARE IN mm. 2. ROUND OFF ALL SHARP CORNERS WITH 0.40 mm. 3. TOLERANCES WILL BE AS PER IS:6477-1983, UNLESS OTHERWISE SPECIFIED		SCALE		1:1
		AREA mm ²		1897.65
		PERIMETER mm.		315.313
		WEIGHT kg/m		5.124
PARTY'S NAME	MARVEL MECHATRONICS PVT.LTD., CHENNAI	DRAWING No.	SECTION No.	
PARTY'S DRAWING No.	AS PER DRAWING & REQUIREMENT	P-12307-2	-	
ALLOY & TEMPER	HE9 WP	S3584	S3584(ISSUE-2)	
		28150	28150	
DESCRIPTION	TELECOMMUNICATION SECTION			