

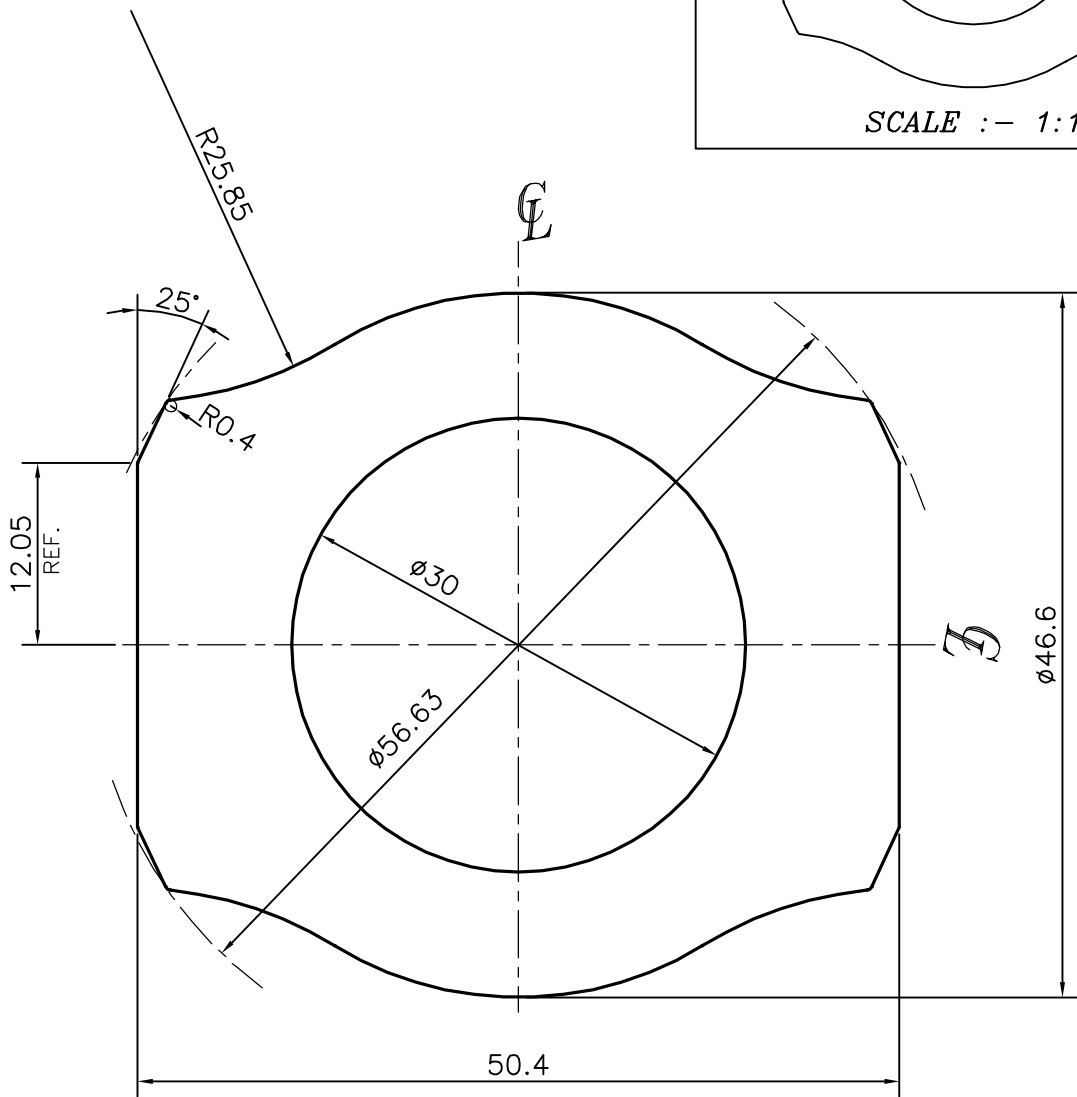

P-12191
S3550
28152

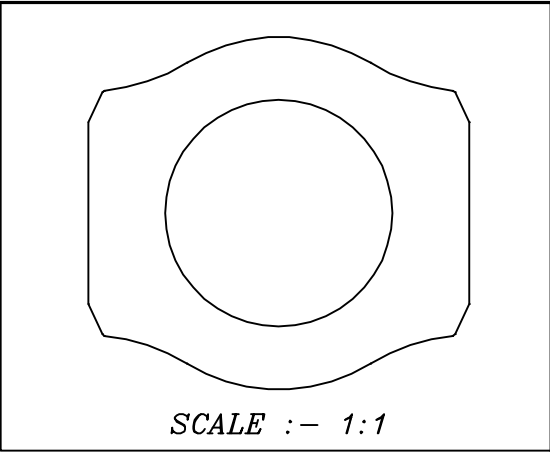

1. STRAIGHTNESS=1.5mm/M
2. TWIST=1.5mm/M
3. OVALITY=±0.50mm

 SYMBOL OF QUALITY AN ISO 9001 COMPANY	JINDAL ALUMINIUM LTD. BANGALORE-560073 (INDIA)	DRAWN	NAME	DATE
		CHECKED	PARVESH	31-10-2012
1. ALL DIMENSIONS ARE IN mm. 2. ROUND OFF ALL SHARP CORNERS WITH 0.40 mm. 3. TOLERANCES WILL BE AS PER IS:6477-1983 , UNLESS OTHERWISE SPECIFIED		APPROVED	S.S.GARG	08-11-2012
		SCALE		2:1
PARTY'S NAME TITAN INDUSTRIES LTD., HOSUR		AREA mm ²		1262.014
		PERIMETER mm.		164.707
PARTY'S DRAWING No. TS-25-113		WEIGHT kg/m		3.407
		DRAWING No.		
ALLOY & TEMPER 6063 T6		SECTION No.		
		P-12191		-
DESCRIPTION WATCH CASE		S3550		S3550
		28152		28152