

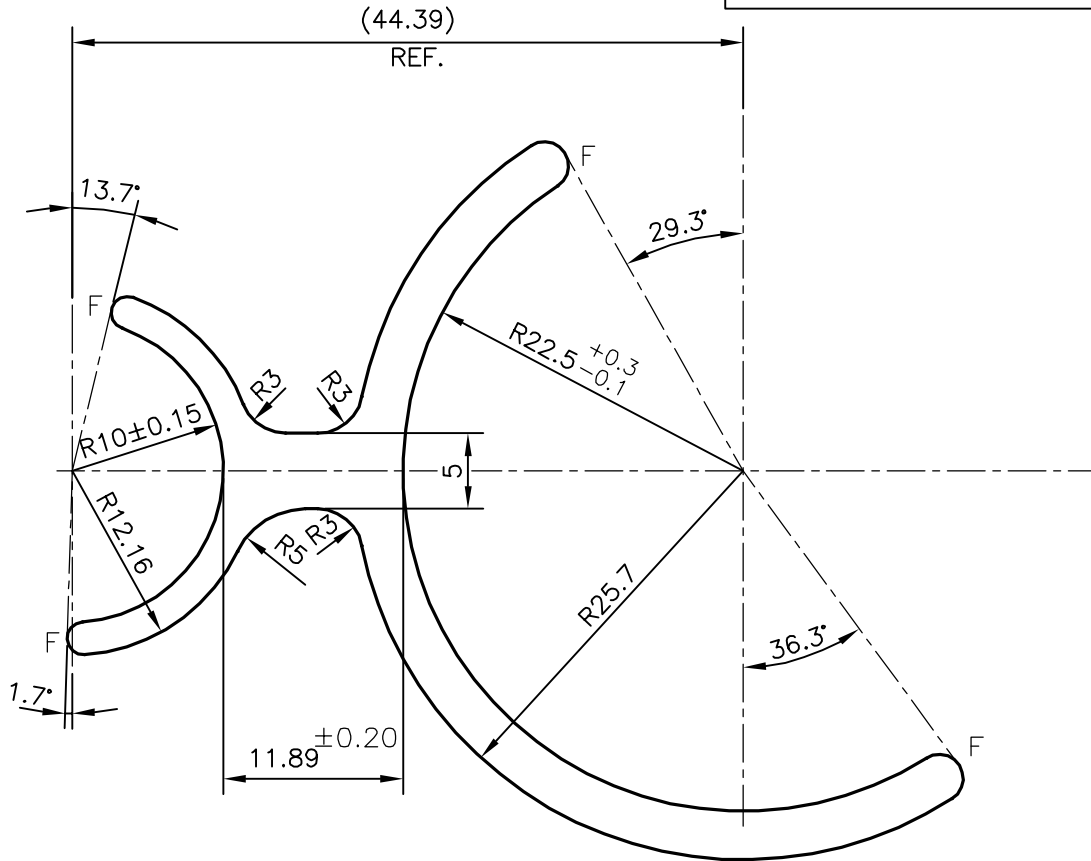

P-12014-1
S3582
28156

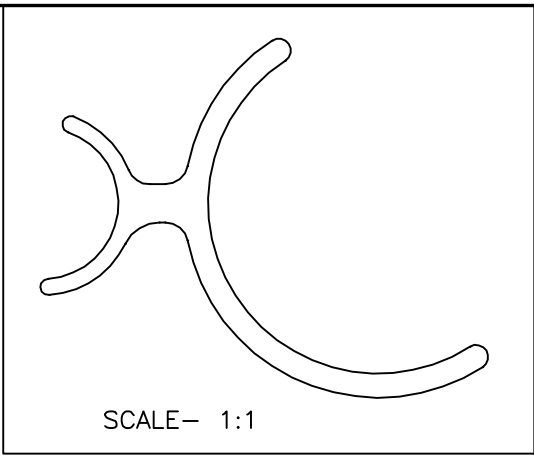

F = FULL RADIUS ( 4 PLACES )

 SYMBOL OF QUALITY AN ISO 9001 COMPANY	<b>JINDAL ALUMINIUM LTD.</b> BANGALORE-560073 (INDIA)		NAME	DATE
		DRAWN	PARVESH	01-12-2012
1. ALL DIMENSIONS ARE IN mm. 2. ROUND OFF ALL SHARP CORNERS WITH 0.40 mm. 3. TOLERANCES WILL BE AS PER BS:EN-755-9 UNLESS OTHERWISE SPECIFIED		CHECKED		
		APPROVED	S.S.GARG	18-12-2012
PARTY'S NAME WONJIN AUTOPARTS INDIA PVT. LTD., MARAMALAI NAGAR		SCALE		2:1
		AREA mm <sup>2</sup>		357.487
PARTY'S DRAWING No. VP AE8H-19732-AB		PERIMETER mm.		228.812
		WEIGHT kg/m		0.965
ALLOY & TEMPER 6005 T5		DRAWING No.		SECTION No.
		P-12014-1		
DESCRIPTION AUTOMOBILE SECTION		S3582		S3582
		28156		28156