

P-12465-1
X1650
28161

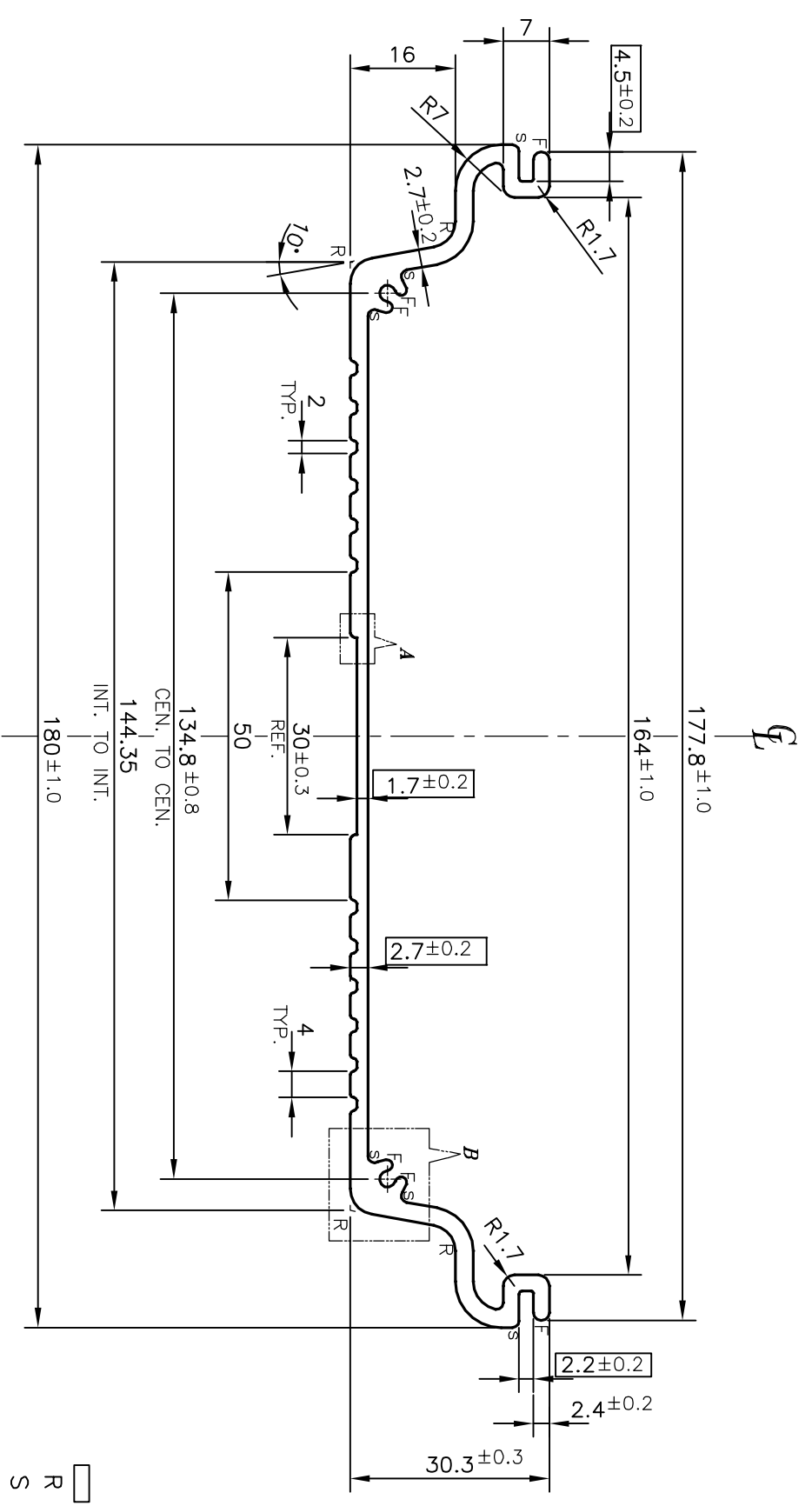
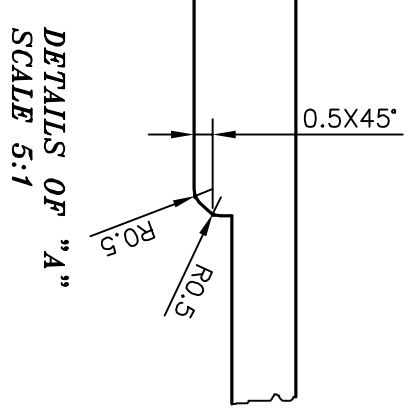
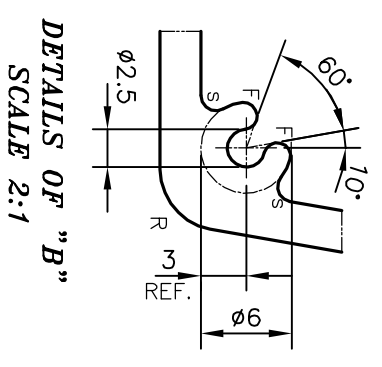

= CRITICAL DIMENSION TO BE MAINTAINED
 R = 4 mm RADIUS (4 PLACES)
 S = 1 mm RADIUS (6 PLACES)
 F = FULL RADIUS (6 PLACES)

		JINDAL ALUMINIUM LTD. BANGALORE-560073 (INDIA)	
SYMBOL OF QUALITY AN ISO 9001 COMPANY			
1. ALL DIMENSIONS ARE IN mm. 2. ROUND OFF ALL SHARP CORNERS WITH 0.50 mm. 3. TOLERANCES WILL BE AS PER BS:EN-12020-2, UNLESS OTHERWISE SPECIFIED			
PARTY'S NAME		LECTRIX MOTORS LTD., GURGAON	
PARTY'S DRAWING No.		AS PER Auto CAD DRAWING	
ALLOY & TEMPER		6063 T6	
DESCRIPTION		MISC. PROFILE	
DRAWN	NAME	DATE	
CHECKED	SRIYATHSA	25-01-2013	
APPROVED	S.S.GARG	29-01-2013	
SCALE		1:1	
AREA mm ²		625.587	
PERIMETER mm.		505.752	
WEIGHT kg/m		1.689	
DRAWING No.		SECTION No.	
P-12465-1			
X1650		X1650	
28161		28161	